

(12) INTERNATIONAL APPLICATION PUBLISHED UNDER THE PATENT COOPERATION TREATY (PCT)

(19) World Intellectual Property Organization
International Bureau



(43) International Publication Date
23 May 2002 (23.05.2002)

PCT

(10) International Publication Number
WO 02/41227 A1

- (51) International Patent Classification⁷: G06F 17/60 (74) Agent: LORBIECKI, Mark, L.; Black Lowe & Graham PLLC, 816 Second Avenue, Seattle, WA 98104 (US).
- (21) International Application Number: PCT/US01/09046 (81) Designated States (national): AE, AG, AL, AM, AT, AU, AZ, BA, BB, BG, BR, BY, BZ, CA, CH, CN, CO, CR, CU, CZ, DE, DK, DM, DZ, EE, ES, FI, GB, GD, GE, GH, GM, HR, HU, ID, IL, IN, IS, JP, KE, KG, KP, KR, KZ, LC, LK, LR, LS, LT, LU, LV, MA, MD, MG, MK, MN, MW, MX, MZ, NO, NZ, PL, PT, RO, RU, SD, SE, SG, SI, SK, SL, TJ, TM, TR, TT, TZ, UA, UG, UZ, VN, YU, ZA, ZW.
- (22) International Filing Date: 21 March 2001 (21.03.2001)
- (25) Filing Language: English
- (26) Publication Language: English
- (30) Priority Data: 09/531,237 21 March 2000 (21.03.2000) US (84) Designated States (regional): ARIPO patent (GH, GM, KE, LS, MW, MZ, SD, SL, SZ, TZ, UG, ZW), Eurasian patent (AM, AZ, BY, KG, KZ, MD, RU, TJ, TM), European patent (AT, BE, CH, CY, DE, DK, ES, FI, FR, GB, GR, IE, IT, LU, MC, NL, PT, SE, TR), OAPI patent (BF, BJ, CF, CG, CI, CM, GA, GN, GW, ML, MR, NE, SN, TD, TG).
- (71) Applicant: HEALTH HERO NETWORK, INC. [US/US]; Suite 111, 2570 West El Camino Real, Mountain View, CA 94040 (US).
- (72) Inventor: BROWN, Stephen, J.; 3324 Woodside Road, Woodside, CA 94062 (US). Published: with international search report

[Continued on next page]

(54) Title: NETWORKED SYSTEM FOR INTERACTIVE COMMUNICATION AND REMOTE MONITORING OF INDIVIDUALS

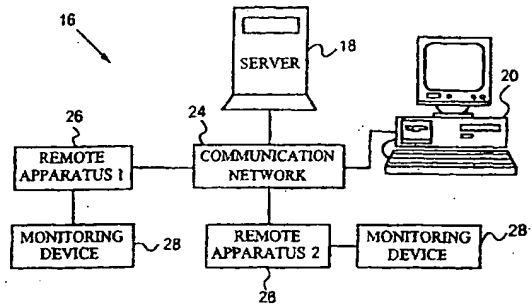

(57) Abstract: A system and method for remotely interacting with an individual. The system includes a server (18), a remote interface device (20) for assigning in the server (18) a set of queries (57) to be answered by the individual, a remote apparatus (26) for interacting with the individual and a digital broadcaster in communication with the server and the remote apparatus (26). The remote apparatus (26) is in communication with the server (18) via a communication network. The server (18), executable by the remote apparatus (26) generates a script program (40) from the assigned set of queries to the individual, receives responses (42) to the set of queries and transmits the responses (42) from the remote apparatus (26) over the communication network.

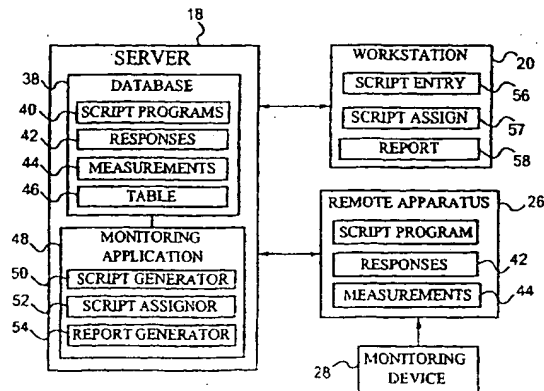

WO 02/41227 A1



For two-letter codes and other abbreviations, refer to the "Guidance Notes on Codes and Abbreviations" appearing at the beginning of each regular issue of the PCT Gazette.

5

NETWORKED SYSTEM FOR INTERACTIVE
COMMUNICATION AND REMOTE MONITORING OF
INDIVIDUALS

10

PRIORITY CLAIM

This application is a continuation of U.S. Patent Application No. 09/237,194, which is a continuation of U.S. Patent No. 5,899,855, which is a continuation of U.S. Patent Application No. 08/233,397, now abandoned, which is a continuation-in-part of U.S. Patent No. 5,307,263. This application is also a continuation U.S. Patent Application No. 09/300,856, which is a divisional of U.S. Patent No. 5,997,476, which is a continuation-in-part of U.S. Patent No. 5,897,493, which claims benefit of Provisional Applications 60/041,746 and 60/041,751 both filed March 28, 1997. All of the above are hereby incorporated by reference.

20

FIELD OF THE INVENTION

The present invention relates generally to communication systems for remote monitoring of individuals, and in particular to a networked system for remotely monitoring individuals and for communicating information to the individuals through the use of script programs.

25

BACKGROUND OF THE INVENTION

In the United States alone, over 100 million people have chronic health conditions, accounting for an estimated \$700 billion in annual medical costs. In

an effort to control these medical costs, many healthcare providers have initiated outpatient or home healthcare programs for their patients. The potential benefits of these programs are particularly great for chronically ill patients who must treat their diseases on a daily basis. However, the success of these programs is dependent upon the ability of the healthcare providers to monitor the patients remotely to avert medical problems before they become complicated and costly. Further, success requires compliance with the program, which is often dependent on providing messages or other reminders to patients so that they will stay with the program. Unfortunately, no convenient and cost effective monitoring system exists to accomplish these objectives. While these problems are particularly acute for the poor and the elderly, all demographic groups could significantly benefit from remote communication and monitoring systems.

Prior attempts to monitor patients remotely have included the use of personal computers and modems to establish communication between patients and healthcare providers, either directly or via an Internet site. However, computers are too expensive to give away and the patients who already own computers are only a fraction of the total population.

Other attempts to monitor patients remotely have included the use of medical monitoring devices with built-in modems. Examples of such monitoring devices include blood glucose meters, respiratory flow meters, and heart rate monitors. While these devices can be quite successful, their multimedia capabilities are often limited. In addition, many patients simply may prefer to interact with a device they are more familiar with, such as a television.

Prior attempts to monitor patients remotely have also included the use of interactive telephone or video response systems. Such interactive systems are disclosed in U.S. Pat. No. 5,390,238 issued to Kirk et al. on Feb. 14, 1995, U.S. Pat. No. 5,434,611 issued to Tamura on Jul. 18, 1995, and U.S. Pat. No. 5,441,047 issued to David et al. on Aug. 15, 1995. One disadvantage of these systems is that they either require a patient to call in to a central facility to be

monitored or require the central facility to call the patient according to a rigid monitoring schedule.

If the patients are required to call the central facility, only the compliant patients will actually call regularly to be monitored. Non-compliant patients will typically wait until an emergency situation develops before contacting their healthcare provider, thus defeating the purpose of the monitoring system. If the central facility calls each patient according to a monitoring schedule, it is intrusive to the patient's life and resistance to the monitoring grows over time. Further, it is difficult to identify each patient uniquely using these systems. Moreover, these systems are generally incapable of collecting medical data from monitoring devices, such as blood glucose meters, respiratory flow meters, or heart rate monitors.

As such, there exists a need for a simple and inexpensive system for remotely monitoring patients and for easily communicating information to the patients. There is also a need to encourage patient's compliance with a prescribed treatment plan.

SUMMARY

The present invention provides a system for remotely interacting with an individual. The system includes a server, a remote interface device for assigning in the server a set of queries to be answered by the individual, a remotely programmable apparatus for interacting with the individual and a broadcaster in communication with the server and the remotely programmable apparatus.

The remotely programmable apparatus is in communication with the server via a communication network. The server includes a script-generating component for generating a script program from the assigned set of queries. The script program is executable by the remotely programmable apparatus to communicate the set of queries to the individual, to receive responses to the set of queries, and to transmit the responses from the remotely programmable apparatus to the server over the communication network. With respect to this invention,

“remotely programmable” means capable of executing instructions received from a remote location, such as, for example, the ability to execute a script program received from a remote location. The server also includes a database device connected to the script-generating component for storing the script program and the responses to the set of queries. The broadcaster receives a broadcast selection from the remotely programmable apparatus and the script program from the server, determines program content according to the broadcast selection, combines the script program with the determined program content to create a digital broadcast program and transmits the broadcast program.

10 The remotely programmable apparatus includes a communication component for receiving the broadcast program and for transmitting the responses to the script program to the server, a user interface for communicating the set of queries to the individual and for receiving the responses to the set of queries, a memory device for storing the script program and the responses to the set of queries, and a processor. The processor is in communication with the communication component, the user interface and the memory device. The processor processes the broadcast program and presents the script program and the broadcast content according to the processing, executes the script program to communicate the set of queries to the individual, to receive the responses to the set of queries, and to transmit the responses to the server.

20 In accordance with a further aspect of the present invention, the program content is entertainment content, information content, advertisement content or a combination of the above.

25 In accordance with another aspect of the present invention, the user interface comprises a display and the processor determines if a script program is included in the broadcast program and presents an icon on the display indicating a script program is included in the broadcast program.

30 By using the entertainment medium of interactive television with its ability to receive a large bandwidth of data, the present invention can more easily communicate interactive entertaining/educational information to potential and

existing patients. The interactive nature of the received data makes it easy for a user to access interactive programs related to corresponding entertainment/advertisement content or related to user adherence to a predefined regimen.

5

BRIEF DESCRIPTION OF THE DRAWINGS

The foregoing aspects and many of the attendant advantages of this invention will become more readily appreciated as the same becomes better understood by reference to the following detailed description, when taken in conjunction with the accompanying drawings, wherein:

10

FIGURE 1 is a block diagram of networked system formed in accordance with a first embodiment of the present invention;

FIGURE 2 is a block diagram illustrating the interaction of the components of the system of FIGURE 1;

15

FIGURE 3 is a perspective view of a remotely programmable apparatus of the system of FIGURE 1;

FIGURE 4 is a block diagram illustrating the components of the apparatus of FIGURE 3;

20

FIGURE 5 is a script entry screen according to the preferred embodiment of the invention;

FIGURE 6A is a listing of a sample script program according to the preferred embodiment of the invention;

FIGURE 6B is a continuation of the listing of FIGURE 6A;

25

FIGURE 7 is a script assignment screen according to the preferred embodiment of the invention

FIGURE 8 is a sample query appearing on the apparatus of FIGURES 1A-D;

FIGURE 9 is a sample prompt appearing on the display of the apparatus of FIGURE 3;

FIGURE 10 is a sample report displayed on a workstation of the system of FIGURES 1A-D;

FIGURE 11A is a flow chart illustrating the steps included in a monitoring application executed by the server of FIGURES 1A-D according to the present invention;

FIGURE 11B is a continuation of the flow chart of FIGURE 11A

FIGURE 12A is a flow chart illustrating the steps included in the script program of FIGURES 6A-6B;

FIGURE 12B is a continuation of the flow chart of FIGURE 12;

FIGURE 13 is a perspective view of a remotely programmable apparatus according to an embodiment of the present invention;

FIGURE 14 is a sample prompt appearing on a display of the apparatus of FIGURE 13;

FIGURE 15 is a block diagram illustrating the components of the apparatus of FIGURE 13;

FIGURE 16 is a schematic block diagram illustrating the interaction of the server of FIGURES 1A-D with the apparatus of FIGURE 3 according to another embodiment of the present invention;

FIGURE 17 is a first sample message appearing on the display of the apparatus of FIGURE 3;

FIGURE 18 is a second sample message appearing on the display of the apparatus of FIGURE 3;

FIGURE 19 is a script entry screen according to an embodiment of the present invention;

FIGURES 20 and 21 are block diagrams of alternate embodiments of the present invention;

FIGURE 22 is a flow chart illustrating the process performed by the system of FIGURES 21; and

FIGURES 23 and 24 are example broadcast programming presentations with an included script program.

DETAILED DESCRIPTION

The present invention provides a system and method for remotely monitoring individuals and for increasing individual use of health programs. In a first embodiment of the invention, the individuals are patients and the system is used to collect data relating to the health status of the patients. However, it is to be understood that the invention is not limited to remote monitoring of patients. The system and method of the invention may be used for any type of remote monitoring and program adherence application. The invention may also be implemented as an automated messaging system for communicating information to individuals, as will be discussed in an alternative embodiment below.

A first embodiment of the invention is illustrated in FIGURES 1A and 2-12. Referring to FIGURE 1, a networked system 16 includes a server 18 and a workstation 20 connected to the server 18 through a communication network 24. The server 18 is preferably a world wide web server and the communication network 24 is preferably the Internet. It will be apparent to one skilled in the art that the server 18 may comprise a single stand-alone computer or multiple computers distributed throughout a network. The workstation 20 is preferably a personal computer, remote terminal, or web TV unit connected to the server 18 via the Internet. The workstation 20 functions as a remote interface for entering in the server 18 messages and queries to be communicated to the patients.

The system 16 also includes multiple remotely programmable apparatus, such as first and second apparatuses 26 for monitoring multiple patients. Each apparatus 26 is designed to interact with a patient in accordance with script programs received from the server 18. Each apparatus 26 is in communication with the server 18 through the communication network 24, preferably the Internet. Alternatively, each apparatus 26 may be placed in communication with the server 18 via wireless communication networks, cellular networks, telephone networks, satellite networks or any other network which allows each apparatus 26 to exchange data with the server 18. It is to be understood that the system 16 may

include any number of remotely programmable apparatuses for monitoring any number of patients.

In the preferred embodiment, each patient to be monitored is also provided with a monitoring device 28. The monitoring device 28 is designed to produce
5 measurements of a physiological condition of the patient, record the measurements, and transmit the measurements to the patient's remotely programmable apparatus through a standard connection cable 30. Examples of suitable monitoring devices 28 include blood glucose meters, respiratory flow meters, blood pressure cuffs, electronic weight scales, and pulse rate monitors.
10 Such monitoring devices are well known in the art. The specific type of monitoring device 28 provided to each patient is dependent upon the patient's disease or health treatment needs. For example, diabetes patients are provided with a blood glucose meter for measuring blood glucose concentrations, asthma patients are provided with respiratory flow meters for measuring peak flow rates,
15 obesity patients are provided with weight scales, etc.

FIGURE 2 shows the server 18, the workstation 20, and the apparatus 26 in greater detail. The server 18 includes a database 38 for storing script programs 40. The script programs 40 are executed by each apparatus 26, to communicate queries and messages to a patient, receive responses 42 to the
20 queries, collect monitoring device measurements 44, and to transmit responses 42 and measurements 44 to the server 18. The database 38 is designed to store responses 42 and measurements 44. The database 38 further includes a look-up table 46. The table 46 contains a list of the patients to be monitored, and for each patient, a unique patient identification code and a respective pointer to the script
25 program assigned to the patient. Each remotely programmable apparatus 26 is designed to execute assigned script programs 40 received from the server 18.

The script programs may include queries, reminder messages, informational statements, useful quotations, or other information of benefit to the patient. See Appendix A for example script programs.

FIGURES 3-4 show the structure of a remotely programmable apparatus 26 according to the preferred embodiment. Referring to FIGURE 3, the apparatus 26 includes a housing 62. The housing 62 is sufficiently compact to enable the apparatus 26 to be hand-held and carried by a patient. The apparatus
5 26 also includes a display 64 for displaying queries and prompts to the patient. In the preferred embodiment, the display 64 is a liquid crystal display (LCD).

The apparatus 26 includes four user input buttons 70A, 70B, 70C, and 70D that are located adjacent to the display 64. The user input buttons 70A-D are for entering in the apparatus 26 responses 42 to the queries and prompts. In the
10 preferred embodiment, the user input buttons 70A-D are momentary contact push buttons. In alternative embodiments, user input buttons 70A-D may be replaced by switches, keys, a touch sensitive display screen, or any other data input device.

Three monitoring device jacks 68A, 68B, and 68C are located on a surface of housing 62. The device jacks 68A-C are for connecting the apparatus 26 to a
15 number of monitoring devices 28, such as blood glucose meters, respiratory flow meters, or blood pressure cuffs (not shown in FIGURE 3). The apparatus 26 also includes a modem jack 66 for connecting the apparatus 26 to a telephone jack through a standard connection cord (not shown). The apparatus 26 further includes a visual indicator, such as a light emitting diode (LED) 74. The LED 74
20 is for visually notifying the patient that he or she has unanswered queries stored in the apparatus 26.

FIGURE 4 is a schematic block diagram illustrating the components of the apparatus 26 in greater detail. The apparatus 26 includes a microprocessor 76 and a memory 80 connected to the microprocessor 76. The memory 80 is preferably a
25 non-volatile memory, such as a serial EEPROM. The memory 80 stores script programs 40 received from the server 18, measurements 44 received from the monitoring device 28, responses 42 to queries, and the patient's unique identification code. The microprocessor 76 also includes built-in read only memory (ROM), which stores firmware for controlling the operation of the
30 apparatus 26. The firmware includes a script interpreter used by the

microprocessor 76 to execute the script programs 40. The script interpreter interprets script commands, which are executed by the microprocessor 76. Specific techniques for interpreting and executing script commands in this manner are well known in the art.

5 The microprocessor 76 is preferably connected to memory 80 using a standard two-wire interface. The microprocessor 76 is also connected to the user input buttons 70, the LED 74, a clock 84, and a display driver 82. The clock 84 indicates the current date and time to the microprocessor 76. For clarity of illustration, clock 84 is shown as a separate component, but is preferably built into
10 the microprocessor 76. The display driver 82 operates under the control of the microprocessor 76 to display information on the display 64. The microprocessor 76 is preferably a PIC 16C65 processor, which includes a universal asynchronous receiver transmitter (UART) 78. The UART 78 is for communicating with a modem 86 and a device interface 90. A CMOS switch 88
15 under the control of the microprocessor 76 alternately connects the modem 86 and the interface 90 to the UART 78.

 The modem 86 is connected to a telephone jack 22 through the modem jack 66. The modem 86 is for exchanging data with the server 18 through the communication network 24. The data includes the script programs 40 which are
20 received from the server 18 as well as the responses 42 to queries, the device measurements 44, the script identification codes, and the patient's unique identification code, which the modem 86 transmits to the server 18. The modem 86 is preferably a complete 28.8 K modem commercially available from Cermetek, although any suitable modem may be used.

25 The device interface 90 is connected to the device jacks 68A, 68B, and 68C. The device interface 90 is for interfacing with a number of monitoring devices 28, such as blood glucose meters, respiratory flow meters, blood pressure cuffs, weight scales, or pulse rate monitors, through device jacks 68A-C. The device interface 90 operates under the control of the microprocessor 76 to collect
30 measurements 44 from the monitoring devices 28 and to output the measurements

to the microprocessor 76 for storage in the memory 80. In the preferred embodiment, the interface 90 is a standard RS232 interface. For simplicity of illustration, only one device interface 90 is shown in FIGURE 4. However, in alternative embodiments, the apparatus 26 may include multiple device interfaces
5 to accommodate monitoring devices that have different connection standards.

Referring again to FIGURE 2, the server 18 includes a monitoring application 48. The monitoring application 48 is a controlling software application executed by the server 18 to perform the various functions described below. The application 48 includes a script generator 50, a script assignor 52, and
10 a report generator 54. The script generator 50 is designed to generate the script programs 40 from script information entered through the workstation 20. The script information is entered through a script entry screen 56. In the preferred embodiment, script entry screen 56 is implemented as a web page on the server 18. The workstation 20 includes a web browser for accessing the web page
15 to enter the script information.

FIGURE 5 illustrates the script entry screen 56 as it appears on the workstation 20. The screen 56 includes a script name field 92 for specifying the name of a script program to be generated. The screen 56 also includes entry fields
20 94 for entering a set of queries to be answered by a patient. Each entry field 94 has corresponding response choice fields 96 for entering response choices for the query. The screen 56 further includes check boxes 98 for selecting a desired monitoring device 28, such as a blood glucose meter, respiratory flow meter, or blood pressure cuff, from which to collect measurements 44.

The screen 56 additionally includes a connection time field 100 for
25 specifying a prescribed connection time at which each apparatus 26 executing the script is to establish a subsequent communication link to the server 18. The connection time is preferably selected to be the time at which communication rates are the lowest, such as 3:00 AM. The screen 56 also includes a CREATE SCRIPT button 102 for instructing script generator 50 to generate a script program

40 from the information entered in screen 56. The screen 56 further includes a CANCEL button 104 for canceling the information entered in screen 56.

In the preferred embodiment, each script program 40 created by script generator 50 conforms to the standard file format used on UNIX systems. In the standard file format, each command is listed in the upper case and followed by a colon. Every line in the script program 40 is terminated by a linefeed character {LF}, and only one command is placed on each line. The last character in the script program 40 is a UNIX end of file character {EOF}. Table 1 shows an exemplary listing of script commands used in the preferred embodiment of the invention.

TABLE 1

15	SCRIPT COMMANDS Command Description
	CLS: {LF} Clear the display.
20	ZAP: {LF} Erase from memory the last set of query responses recorded.
25	LED: b{LF} Turn the LED on or off, where b is a binary digit of 0 or 1.
30	An argument of 1 turns on the LED, and an argument of 0 turns off the LED.
	DISPLAY: Display the text following the DISPLAY command. {chars} {LF}

INPUT: Record a button press. The m's represent a button
 mask
 mmmm{LF} pattern for each of the four input buttons. Each m
 contains an "X" for disallowed buttons or an "0" for
 5 allowed buttons. For example, INPUT: OXOX{LF}
 allows the user to press either button #1 or #3.
 WAIT: Wait for any one button to be pressed, then continue
 {LF} executing the script program.
 COLLECT: Collect measurements from the monitoring device
 10 device{LF}
 specified in the COLLECT command. The user is
 preferably prompted to connect the specified
 monitoring
 device to the apparatus and press a button to
 15 continue.
 NUMBER: Assign a script identification code to the script
 program.
 aaaa{LF} The script identification code from the most recently
 20 executed NUMBER statement is subsequently
 transmitted to the server along with the query
 responses
 and device measurements. The script identification
 code
 identifies to the server which script program was
 25 most
 recently executed by the remote apparatus.
 DELAY: Wait until time t specified in the DELAY command,
 t{LF} usually the prescribed connection time.
 CONNECT: Perform a connection routine to establish a
 30 {LF} communication link to the server, transmit the
 patient
 identification code, query responses, device
 measurements, and script identification code to the
 server, and receive and store a new script program.
 35 When
 the server instructs the apparatus to disconnect, the
 script

interpreter is restarted, allowing the new script
program
to execute.

0

5

The script commands illustrated in Table 1 are representative of the preferred embodiment and are not intended to limit the scope of the invention. After consideration of the ensuing description, it will be apparent to one skilled in the art many other suitable scripting languages and sets of script commands may
10 be used to implement the invention.

The script generator 50 preferably stores a script program template which it uses to create each script program 40. To generate a script program 40, the script generator 50 inserts into the template the script information entered in the screen 56. For example, FIGURES 6A-6B illustrate a sample script program 40
15 created by the script generator 50 from the script information shown in FIGURE 5.

The script program 40 includes display commands to display the queries and response choices entered in fields 94 and 96, respectively. The script program 40 also includes input commands to receive responses 42 to the queries. The
20 script program 40 further includes a collect command to collect device measurements 44 from the monitoring device 28 specified in the check boxes 98. The script program 40 also includes commands to establish a subsequent communication link to the server 18 at the connection time specified in field 100
FIGURE 5. The steps included in the script program 40 are also shown in the
25 flow chart of FIGURES 12A-12B and will be discussed in the operation section below.

Referring again to FIGURE 2, the script assignor 52 is used to assign script programs 40 to the patients. The script programs 40 are assigned in accordance with script assignment information entered through workstation 20.
30 The script assignment information is entered through a script assignment screen 57, which is preferably implemented as a web page on the server 18.

FIGURE 7 illustrates a sample script assignment screen 57 as it appears on workstation 20. The screen 57 includes check boxes 106 for selecting a script program 40 to be assigned, and check boxes 108 for selecting the patients to whom the script program is to be assigned. The screen 57 also includes an
5 ASSIGN SCRIPT button 112 for entering the assignments. When button 112 is pressed, the script assignor 52 creates and stores for each patient selected in check boxes 108 a respective pointer to the script program 40 selected in the check boxes 106. Each pointer is stored in the patient look-up table 46 of the database 38. The screen 57 further includes an ADD SCRIPT button 110 for
10 accessing the script entry screen and a DELETE SCRIPT button 114 for deleting a script program 40.

Referring again to FIGURE 2, the report generator 54 is designed to generate a patient report 58 from the responses 42 and the device measurements 44 received in the server 18. The patient report 58 is displayed on the workstation
15 20. FIGURE 10 shows a sample patient report 58 produced by the report generator 54 for a selected patient. The patient report 58 includes a graph 116 of the device measurements 44 received from the patient, as well as a listing of the responses 42 received from the patient. Specific techniques for writing a report generator program to display data in this manner are well known in the art.

20 The operation of the preferred embodiment is illustrated in FIGURES 1-12. FIGURE 11A is a flow chart illustrating steps included in the monitoring application executed by the server 18. FIGURE 11B is a continuation of the flow chart of FIGURE 11A. In step 202, the server 18 determines if new script information has been entered through the script entry screen 56. If new script
25 information has not been entered, the server 18 proceeds to step 206. If new script information has been entered, the server 18 proceeds to step 204.

As shown in FIGURE 5, the script information includes a set of queries, and for each of the queries, corresponding response choices. The script information also includes a selected monitoring device type from which to collect
30 device measurements 44. The script information further includes a prescribed

connection time for each apparatus to establish a subsequent communication link to the server 18. The script information is generally entered in the server 18 by a healthcare provider, such as the patients' physician or case manager. Of course, any person desiring to communicate with the patients may also be granted access
5 to the server 18 to create and assign script programs 40. Further, it is to be understood that system 16 may include any number of remote interfaces for entering script generation and script assignment information in the server 18.

In step 204, the script generator 50 generates a script program from the information entered in the screen 56. The script program is stored in the
10 database 38. Steps 202 and 204 are preferably repeated to generate multiple script programs, e.g. a script program for diabetes patients, a script program for asthma patients, etc. Each script program corresponds to a respective one of the sets of queries entered through the script entry screen 56. Following step 204, the server 18 proceeds to step 206.

15 In step 206, the server 18 determines if new script assignment information has been entered through the assignment screen 57. If new script assignment information has not been entered, the server 18 proceeds to step 210. If new script assignment information has been entered, the server 18 proceeds to step 208. As shown in FIGURE 7, the script programs are assigned to each patient by selecting
20 a script program through check boxes 106, selecting the patients to whom the selected script program is to be assigned through check boxes 108, and pressing the ASSIGN SCRIPT button 112. When button 112 is pressed, the script assignor 52 creates for each patient selected in the check boxes 108 a respective pointer to the script program selected in the check boxes 106. In step 208, each pointer is
25 stored in the look-up table 46 of the database 38. Following step 208, the server 18 proceeds to step 210.

In step 210, the server 18 determines if any of the apparatuses are remotely connected to the server. Each patient to be monitored is preferably provided with his or her own remotely programmable apparatus, which has the patient's unique
30 identification code, stored therein. Each patient is thus uniquely associated with a

respective one of the apparatuses. If none of the apparatuses is connected, the server 18 proceeds to step 220.

If an apparatus is connected, the server 18 receives from the apparatus the patient's unique identification code in step 212. In step 214, the server 18 receives
5 from the apparatus the query responses 42, device measurements 44, and script identification code recorded during execution of a previously assigned script program. The script identification code identifies to the server 18 which script program was executed by the apparatus to record the query responses 42 and device measurements 44. The responses, device measurements, and script
10 identification code are stored in the database 38.

In step 216, the server 18 uses the patient identification code to retrieve from the table 46 the pointer to the script program assigned to the patient. The server 18 then retrieves the assigned script program from the database 38. In step 218, the server 18 transmits the assigned script program to the patient's remotely
15 programmable apparatus through the communication network 24. Following step 218, the server 18 proceeds to step 220.

In step 220, the server 18 determines if a patient report request has been received from the workstation 20. If no report request has been received, the server 18 returns to step 202. If a report request has been received for a selected
20 patient, the server 18 retrieves from the database 38 the measurements 44 and query responses 42 last received from the patient, step 222. In step 224, the server 18 generates and displays the patient report 58 on the workstation 20. As shown in FIGURE 10, the report 58 includes the device measurements 44 and query responses 42 last received from the patient. Following step 224, the
25 server 18 returns to step 202.

FIGURES 12A-12B illustrate the steps included in the script program executed by the apparatus 26. Before the script program is received, the apparatus 26 is initially programmed with the patient's unique identification code and the script interpreter used by microprocessor 76 to execute the script program. The
30 initial programming may be achieved during manufacture or during an initial

connection to the server 18. Following initial programming, the apparatus 26 receives from the server 18 the script program assigned to the patient associated with the apparatus 26. The script program is received by the modem 86 through a first communication link and stored in the memory 80.

5 In step 302, microprocessor 76 assigns a script identification code to the script program and stores the script identification code in the memory 80. The script identification code is subsequently transmitted to the server 18 along with the query responses 42 and the device measurements 44 to identify to the server 18 which script program was most recently executed by apparatus 26. In
10 step 304, the microprocessor 76 lights LED 74 to notify the patient that he or she has unanswered queries stored in the apparatus 26. The LED 74 preferably remains lit until the patient answers the queries. In step 306, the microprocessor 76 erases from the memory 80 the last set of query responses recorded.

In step 308, the microprocessor 76 prompts the patient by displaying on
15 the display 64 "ANSWER QUERIES NOW? PRESS ANY BUTTON TO START". In step 310, the microprocessor 76 waits until a reply to the prompt is received from the patient. When a reply is received, the microprocessor 76 proceeds to step 312. In step 312, the microprocessor 76 executes successive display and input commands to display the queries and response choices on the
20 display 64 and to receive responses to the queries.

FIGURE 8 illustrates a sample query and its corresponding response choices as they appear on the display 64. The response choices are positioned on the display 64 such that each response choice is located proximate a respective one of input buttons 70A-D. In the preferred embodiment, each response choice
25 is displayed immediately above a respective input button 70A-D. The patient presses the button 70A-D corresponding to his or her response. The microprocessor 76 stores each response in the memory 80.

In steps 314-318, the microprocessor 76 executes commands to collect the device measurements 44 from a selected the monitoring device 28. The script
30 program specifies the selected monitoring device from which to collect the

measurements. In step 314, the microprocessor 76 prompts the patient to connect the selected monitoring device 28, for example a blood glucose meter, to one of device jacks 68A-C. A sample prompt is shown in FIGURE 9. In step 316, the microprocessor 76 waits until a reply to the prompt is received from the patient.

5 When a reply is received, the microprocessor 76 proceeds to step 318. The microprocessor 76 also connects the UART 78 to the interface 90 through the switch 88. In step 318, the microprocessor 76 collects device measurements 44 from the monitoring device 28 through the interface 90. The measurements 44 are stored in the memory 80.

10 In step 320, the microprocessor 76 prompts the patient to connect the apparatus 26 to the telephone jack 22 so that the apparatus 26 may connect to the server 18 at the prescribed connection time. In step 322, the microprocessor 76 waits until a reply to the prompt is received from the patient. When a reply is received, the microprocessor 76 turns off the LED 74 in step 324. In step 326, the
15 microprocessor 76 waits until it is time to connect to the server 18. The microprocessor 76 compares the connection time specified in the script program to the current time output by the clock 84. When it is time to connect, the microprocessor 76 connects the UART 78 to the modem 86 through the switch 88.

In step 328, the microprocessor 76 establishes a subsequent
20 communication link between the apparatus 26 and the server 18 through the modem 86 and the communication network 24. If the connection fails for any reason, the microprocessor 76 repeats step 328 to get a successful connection. In step 330, the microprocessor 76 transmits the device measurements 44, query responses 42, script identification code, and patient identification code stored in
25 the memory 80 to the server 18 through the subsequent communication link. In step 332, the microprocessor 76 receives through the modem 86 a new script program from the server 18. The new script program is stored in the memory 80 for subsequent execution by the microprocessor 76. Following step 332, the script program ends.

One advantage of the monitoring system of the present invention is that it allows each patient to select a convenient time to respond to the queries, so that the monitoring system is not intrusive to the patient's schedule. A second advantage of the monitoring system is that it incurs very low communications charges because each remote apparatus connects to the server 18 at times when communication rates are lowest. Moreover, the cost to manufacture each remote apparatus 26 is very low compared to personal computers or internet terminals, so that the monitoring system is highly affordable.

A third advantage of the monitoring system is that it allows each apparatus 10 26 to be programmed remotely through script programs 40. Patient surveys, connection times, display prompts, selected monitoring devices, patient customization, and other operational details of each apparatus 26 may be easily changed by transmitting a new script program 40 to apparatus 26. Moreover, each script program 40 may be easily created and assigned by remotely accessing the 15 server 18 through the Internet. Thus, the invention provides a powerful, convenient, and inexpensive system for remotely monitoring a large number of patients.

FIGURES 13-15 illustrate a second embodiment of the invention in which each remotely programmable apparatus has speech recognition and speech 20 synthesis functionality. FIGURE 13 shows a perspective view of the remotely programmable apparatus 27 according to the second embodiment. The apparatus 27 includes a speaker 72 for audibly communicating queries and prompts to the patient. The apparatus 27 also includes a microphone 118 for receiving spoken responses to the queries and prompts. The apparatus 27 may optionally include a 25 display 64 for displaying prompts to the patient, as shown in FIGURE 14.

FIGURE 15 is a schematic block diagram illustrating the components of the apparatus 27 in greater detail. The apparatus 27 is similar in design to the apparatus 26 of the preferred embodiment except that the apparatus 27 includes an audio processor chip 120 in place of the microprocessor 76. The audio processor

chip 120 is preferably an RSC-164 chip commercially available from Sensory Circuits Inc. of 1735 N. First Street, San Jose, Calif. 95112.

5 The audio processor chip 120 has a microcontroller 122 for executing script programs received from the server 18. A memory 80 is connected to the microcontroller 122. Memory 80 stores the script programs and a script interpreter used by the microcontroller 122 to execute the script programs. The memory 80 also stores measurements received from the monitoring device 28, responses to the queries, script identification codes, and the patient's unique identification code.

10 The audio processor chip 120 also has built in speech synthesis functionality for synthesizing queries and prompts to a patient through the speaker 72. For speech synthesis, the chip 120 includes a digital to analog converter (DAC) 142 and an amplifier 144. The DAC 142 and the amplifier 144 drive the speaker 72 under the control of the microcontroller 122.

15 The audio processor chip 120 further has built in speech recognition functionality for recognizing responses spoken into the microphone 118. Audio signals received through the microphone 118 are converted to electrical signals and sent to a preamp and gain control circuit 128. The preamp and gain control circuit 128 is controlled by an automatic gain control circuit 136, which is in turn controlled by the microcontroller 122. After being amplified by the preamp 128, the electrical signals enter the chip 120 and pass through a multiplexer 130 and an analog to digital converter (ADC) 132. The resulting digital signals pass through a digital logic circuit 134 and enter microcontroller 122 for speech recognition.

20 The audio processor chip 120 also includes a RAM 138 for short-term memory storage and a ROM 140, which stores programs executed by the microcontroller 122 to perform speech recognition and speech synthesis. The chip 120 operates at a clock speed determined by a crystal 126. The chip 120 also includes a clock 84 that provides the current date and time to the microcontroller 122. As in the preferred embodiment, the apparatus 27 includes an LED 74,

display driver 82, modem 86, and device interface 90, all of which are connected to the microcontroller 122.

The operation of the second embodiment is similar to the operation of the preferred embodiment except that queries, response choices, and prompts are audibly communicated to the patient through the speaker 72 rather than being displayed to the patient on the display 64. The operation of the second embodiment also differs from the operation of the preferred embodiment in that responses to the queries and prompts are received through the microphone 118 rather than through user input buttons.

The script programs of the second embodiment are similar to the script program shown in FIGURES 6A-6B, except that each display command is replaced by a speech synthesis command and each input command is replaced by a speech recognition command. The speech synthesis commands are executed by the microcontroller 122 to synthesize the queries, response choices, and prompts through speaker 72. The speech recognition commands are executed by the microcontroller 122 to recognize responses spoken into microphone 118.

For example, to ask the patient how he or she feels and record a response, the microcontroller 122 first executes a speech synthesis command to synthesize through the speaker 72 "How do you feel? Please answer with one of the following responses: very bad, bad, good, or very good." Next, the microcontroller 122 executes a speech recognition command to recognize the response spoken into the microphone 118. The recognized response is stored in the memory 80 and subsequently transmitted to the server. Other than the differences described, the operation and advantages of the second embodiment are the same as the operation and advantages of the preferred embodiment described above.

Although the first and second embodiments focus on querying individuals and collecting responses to the queries, the system of the invention is not limited to querying applications. The system may also be used simply to communicate messages to the individuals. FIGURES 16-19 illustrate a third embodiment in

which the system is used to perform this automated messaging function. In the third embodiment, each script program contains a set of statements to be communicated to an individual rather than a set of queries to be answered by the individual. Of course, it will be apparent to one skilled in the art that the script programs may optionally include both queries and statements.

The third embodiment also shows how the queries and statements may be customized to each individual by merging personal data with the script programs, much like a standard mail merge application. Referring to FIGURE 16, personal data relating to each individual is preferably stored in the look-up table 46 of the database 38. By way of example, the data may include each individual's name, the name of each individual's physician, test results, appointment dates, or any other desired data. As in the preferred embodiment, the database 38 also stores generic script programs 40 created by the script generator 50.

The server 18 includes a data merge program 55 for merging the data stored in table 46 with generic script programs 40. The data merge program 55 is designed to retrieve selected data from table 46 and to insert the data into statements in generic script programs 40, thus creating custom script programs 41. Each custom script program 41 contains statements that are customized to an individual. For example, the statements may be customized with the individual's name, test results, etc. Examples of such customized statements are shown in FIGURES 17-18.

The operation of the third embodiment is similar to the operation of the preferred embodiment except that the script programs are used to communicate messages to the individuals rather than to query the individuals. Each message is preferably a set of statements. Referring to FIGURE 19, the statements may be entered in the server 18 through the script entry screen 56, just like the queries of the preferred embodiment.

Each statement preferably includes one or more insert commands specifying data from table 46 to be inserted into the statement. The insert commands instruct the data merge program 55 to retrieve the specified data from

the database 38 and to insert the data into the statement. For example, the insert commands shown in FIGURE 19 instruct the data merge program 55 to insert a physician name, an appointment date, a patient name, and a test result into the statements. As in the preferred embodiment, each statement may also include one
5 or more response choices, which are entered in fields 96.

Following entry of the statements and response choices, CREATE SCRIPT button 102 is pressed. When the button 102 is pressed, the script generator 50 generates a generic script program from the information entered in the screen 56. The generic script program is similar to the script program shown
10 in FIGURES 6A-6B, except that the display commands specify statements to be displayed rather than queries. Further, the statements include insert commands specifying data to be inserted into the script program. As in the preferred embodiment, multiple script programs are preferably generated, e.g. a generic script program for diabetes patients, a generic script program for asthma patients,
15 etc. The generic script programs are stored in the database 38.

Following generation of the generic script programs, the server 18 receives script assignment information entered through the script assignment screen 57. As shown in FIGURE 7, the script programs are assigned by first selecting one of the generic script programs through the check boxes 106, selecting individuals
20 through the check boxes 108, and pressing the ASSIGN SCRIPT button 112. When the button 112 is pressed, the data merge program 55 creates a custom script program 41 for each individual selected in check boxes 108.

Each custom script program 41 is preferably created by using the selected generic script program as a template. For each individual selected, the data merge program 55 retrieves from the database 38 the data specified in the insert
25 commands. Next, the data merge program 55 inserts the data into the appropriate statements in the generic script program 40 to create a custom script program 41 for the individual. Each custom script program 41 is stored in the database 38.

As each custom script program 41 is generated for an individual, the script
30 assignor 52 assigns the script program 41 to the individual. This is preferably

accomplished by creating a pointer to the custom script program and storing the pointer with the individual's unique identification code in the table 46. When the individual's remotely programmable apparatus connects to the server 18, the server 18 receives from the remotely programmable apparatus 26 the individual's unique identification code. The server 18 uses the unique identification code to retrieve from the table 46 the pointer to the custom script program assigned to the individual. Next, the server 18 retrieves the assigned script program from the database 38 and transmits the script program to the individual's remotely programmable apparatus 26 through the communication network 24.

10 The apparatus receives and executes the script program. The execution of the script program is similar to the execution described in the preferred embodiment, except that statements are displayed to the individual rather than queries. FIGURES 17-18 illustrate two sample statements as they appear on the display 64. Each statement includes a response choice, preferably an acknowledgment such as "OK". After reading a statement, the individual presses the button 70A-D corresponding to the response choice to proceed to the next statement. Alternatively, the script program may specify a period of time that each statement is to be displayed before proceeding to the next statement. The remaining operation of the third embodiment is analogous to the operation of the preferred embodiment described above.

15 Although it is presently preferred to generate a custom script program 41 for each individual as soon as script assignment information is received for the individual, it is also possible to wait until the individual's apparatus 26 connects to the server 18 before generating the custom script program 41. This is accomplished by creating and storing a pointer to the generic script program 40 assigned to the individual, as previously described in the preferred embodiment. When the individual's apparatus 26 connects to the server 18, the data merge program 55 creates a custom script program 41 for the individual from the generic script program 40 assigned to the individual. The custom script program 41 is then sent to the individual's apparatus 26 for execution.

Alternate Embodiments

FIGURES 20 and 21 illustrate alternate embodiments of the invention illustrated in FIGURE 1. In FIGURE 20, the remote apparatus 26 is a personal computer including a processor and a user interface, e.g. display, keyboard, mouse, or other input and output devices (not all shown), that receives the script program, processes the script program and presents the script program for user interaction. For example, the script program requires that the personal computer present an image of a stand-alone remote apparatus 350, such as the Health Buddy™ produced by Health Hero Network, Inc., on the display. The user then interacts with the displayed image of the stand-alone remote apparatus by operating the user interface(s) of the personal computer to select displayed responses. The displayed image of the stand-alone remote apparatus presents a virtual image with the same functionality as the apparatuses 26 and 27, as described above in FIGURES 3 and 13. It can be appreciated to those of ordinary skill in the art that the system of FIGURE 20 provides all or part of the functionality of the apparatuses shown in FIGURES 3 and 13, but does it on a personal computer.

FIGURE 21 includes all the components of the FIGURE 1 and a digital television network 36 in communication with the server 18 and the remote apparatus 26. The remote apparatus 26 of FIGURE 21 is an interactive television system that includes a processing unit 33, such as a satellite broadcast receiving, set-top processor with OpenTV signal processing software, a display 34, such as a television set, and a user interface 35, such as a remote control. The remote apparatus 26, through the processing unit 33, is coupled to the communication network 24, the digital television network 36 and the monitoring device 28.

The processing unit 33 includes a CPU, memory and embedded software for receiving and processing both digital entertainment and advertisement content and digital script programs. Also, the processing unit 33 allows the user to view the entertainment and advertisement content, such as television programming, and interact with (i.e. respond to) the script programs. The script program(s) sent from

the server 18 are viewable on the display 34 as they would appear on the display 64 of apparatus 26 or are viewed on a portion of the display 34. For example, the question with options shown in FIGURE 8 would appear on the display 34. The user makes a selection of one of the choices by using the user interface 35, i.e. giving voice commands that are processed by a voice recognition system, controlling and activating a cursor, etc. Example methods of making a selection are to control a cursor icon on the display screen of the display 34 and activate the cursor icon when it is co-located with one of the choices, to assign different keyboard keys are designated as a different one of the displayed choices.

5

10 Another method is to have the user interface include voice actuation software for processing user voice commands that request selection of a desired choice.

With respect to this invention, a "broadcast" includes any form of delivering the content from a source to many viewers, including transmission over the airwaves or via cable, the Internet, a closed-circuit network, or other means of communication. A "broadcast" does not require multiple persons to watch at once, but rather can include multiple individual and independent viewings, such as in the form of video on demand or access to web pages. Moreover, the term "broadcast" may include a single tailored transmission from a source to a single intended viewer. Accordingly, while a "broadcast" may include a transmission from one point to multiple recipients, it is not limited to that case. Likewise, with respect to this invention, a "broadcast" is "transmitted" in any of the above forms.

15

20

The processing unit 33 is a multimedia processor that receives transmitted broadcast programs from a digital broadcast network 36 via a communication link, such as a satellite or cable link. The processing unit 33 also transmits as well as receives data via the communication network 24. In addition, the multimedia processor has expansion ports to support additional user interface and other devices, such as keyboards, joysticks, trackballs, and to accept add-on circuits for enhanced sound, video, or processing performance.

25

FIGURE 22 is an example for illustrative purposes only of a method for increasing user use of script programs by allowing the user to quickly access the

30

script program during viewing of an entertainment or advertisement program in an interactive TV system. FIGURE 22 illustrates a process performed by the system shown in FIGURE 21. At block 400, the server 18 generates an interactive script program. In an alternate embodiment, the script program is fully or partially
5 created at another remotely coupled computer, such as workstation 20, and added to multimedia content, then the script program and multimedia content is sent to the server 18. In one embodiment, the script program is specialized for a specific user according to a health care professional request or to a predefined health regimen based on user profile information. In an alternate embodiment the script
10 program is generated in relation to entertainment or advertisement content that it will later be broadcasted with. Next, at block 402, the generated script program is combined with digital produced entertainment or advertisement content, i.e. a multimedia presentation, to create digital broadcast programming. The digital broadcast programming is then broadcasted or transmitted over the chosen
15 communication link, block 406. At block 408, the processing unit 33 receives and processes the digital broadcast programming then presents the entertainment or advertisement content and the script program. The processing unit 33 as directed by software instructions previously imbedded in the processing unit 33, included with the digital broadcast programming or a combination of both processes the
20 digital broadcast programming by determining its content and how that content is to be presented on the display 34. For example, the processing unit 33 determines if the script program is to be referenced by an icon over the entertainment content or displayed on a portion of the display with the entertainment content. As part of the presentation from block 408 the user is informed of any script program
25 included in the broadcast programming, block 410. Then, at block 426, the user is presented with the script program after the user selects or activates the indication, e.g. an icon. Lastly, at block 428, the user interacts with the script program by responding to any queries and inputting any requested measurements or other responses. The interaction with the script program is similar to that described
30 above for the system of FIGURE 1. In another embodiment, the script program is

presented in conjunction with the entertainment or advertisement content without requiring the user to select or activate an indicator.

FIGURES 23 and 24 are example images presented on the displays 34 in the system illustrated in FIGURE 22. FIGURE 23 illustrates a screen shot of a broadcast program 250 that includes entertainment content 252, such as a video program on heart surgery, and an icon 254. The icon 254 indicates that a script program is available for the viewer. In order for the viewer to access the script program, the viewer selects the icon 254. The program broadcasted from the broadcast network 24 may have included an entire script program or just a portion of a script program. If the entire script program were included with the broadcast, selection of the icon 254 would begin execution of the script program that was received. However, if only a portion of the script program was received and, for example, that portion only required that the icon 254 be displayed with the entertainment content 252, selection of the icon 254 sends a signal through a back channel, i.e. the link to the communication network 24, to the server 18. The sent signal is a request for the rest of or just more of the script program to be sent to the apparatus 26 either through broadcast network 36 or communication network 24.

FIGURE 23 illustrates a screen shot of a broadcast program 250 that includes entertainment content 252 and a section that presents a script program image 256. In this example the viewer can interact with the script program image 256 while simultaneously viewing the entertainment content 252. As in FIGURE 22 above, the script program may be fully or partially received and processed by the processing unit 33. And again, if it has only been partially received, viewer interaction at a predetermined spot in the displayed interaction process automatically initiates a request through the back channel to the server 18 for the rest of the script program.

Because the broadcast program 250 is a digital broadcast, it can be readily appreciated by those of ordinary skill in the art of digital interactive television, that the entertainment content may be paused until viewer completion of the script

program. The script program which can be sent with an initial broadcast program or during presentation of a previously delivered broadcast program that is being presented on the display may also include instructions to pause the entertainment content until viewer completion of the script program at which time the entertainment program resumes. For example, the viewer's/patient's doctor
5 creates a message at the workstation 20 requesting that the patient as soon as possible send blood pressure measurement readings. This message is generated as a new script program at the server 18. The server 18 then sends the new script program to the broadcast network 36. The broadcast network 36 includes
10 hardware and/or software mechanisms for saving the new script program for inclusion with the next patient requested entertainment or advertisement content to be sent to the patient in the case where the patient is not presently viewing a broadcast from the broadcast network 36 or for just broadcasting the script program alone. If the patient is presently viewing entertainment or advertisement
15 content received from the broadcast network 36, the new script program is received, processed and presented to the patient by the apparatus 26. The received new script program may include instructions to pause the presently viewed entertainment or advertisement content.

If the script program is specified for a particular patient, the server 18 or
20 broadcast network 36 encodes the script program for that patient. The apparatus of that patient includes a decoding component within the processing unit 33 for decoding the encoded script program received with the broadcast program. For example, the script program includes a weight history chart of the patient. The present invention wants only the patient corresponding to this weight history chart
25 to have viewing access. Therefore, it is encoded for transmission and encoded only by the corresponding patient's apparatus 26.

It can be appreciated to one of ordinary skill in the art that this decision, as with the other flow diagram decisions, can be an inherent decision in the processing of the received entertainment/advertisement programming and script
30 program.

The embodiments of FIGURES 20 and 21 may also be implemented without any entertainment or advertisement content and perform the functions as to those that illustrated and described for FIGURE 1.

5 The script programs or entertainment/advertisement programming can be designed for education and training of users. For example, the script program or information content could show a user, such as a patient, how to effectively use a medical treatment device. Also, the script program or information content could describe to users, such as doctors, nurses or anyone other professional, different treatment styles, plans or new medication.

10 A wide variety of information may be collected, delivered and analyzed in accordance with the present invention. For example, abandoned U.S. Patent Application No. 09/378,188 which is a continuation of U.S. Patent No. 5,985,559, and unassigned U.S. Patent Application attorney docket No. HERO-1-1089 which is a continuation of U.S. Patent Application No. 09/041,809 (the text of which are
15 hereby incorporated by reference) discusses information related to disease causes, treatments, and cures. Script programs include a set of queries for requesting data on lifestyle, environment, behavior, drug compliance, drug response over time, and other aspects. This data is then analyzed to identify trends and establish subgroups with similar responses.

20 Individuals' behavioral and environmental information in conjunction with their gene sequence information is analyzed to find drug candidates and drug targets. Individuals previously designated as having a high risk for developing a particular disease are each given an apparatus 26. Queries related to the individuals' behavior and environment are included in a script program sent from
25 a server 18 to the apparatus 26 or from a server 18 to the apparatus 26 through a broadcast network 36. The individuals' responses are sent back to the server 18. The process of collecting individuals' information can take place over a long period of time to ensure accurate data and to allow researchers to observe progression of the disease. A data mining program on the server analyzes the
30 individuals' behavioral and environmental information, as well as their gene

sequence information . Differences in gene sequence information, or in behavioral and environmental factors between individuals who show a severe disease phenotype and those who show a mild severe disease phenotype can then be distinguished and used to develop new drug candidates, targets, or general
5 treatments.

Genetic testing allows an individual to determine whether or not he or she has a predisposition to a certain disease. The degree of expressivity of a certain disease will be determined in part by an individual's environment and lifestyle. The environment and lifestyle information is retrieved from responses to queries
10 sent from the server 18 to the apparatus 26 or from the server 18 to the apparatus 26 through the broadcast network 36. The present invention interprets a patient's gene sequence information and his or her environment and lifestyle to come up with a personalized prognosis. This procedure can be repeated many times over the course of a disease state to monitor a patient's condition. In
15 addition, disease-causing pathogens can also have their genes sequenced. Using these sequences in combination with information about a patient's environment and lifestyle, the present invention comes up with a personalized treatment plan, ideally to eliminate the pathogen. It is also possible to use the procedure described above to monitor the course of the disease-state produced by a
20 pathogen. Finally, a genotype-to-phenotype map or database can be constructed for developing better treatments and aiding in research.

Although the above description contains many specificities, these should not be construed as limitations on the scope of the invention but merely as illustrations of some of the presently preferred embodiments. Many other
25 embodiments of the invention are possible. For example, the scripting language and script commands shown are representative of the preferred embodiment. It will be apparent to one skilled in the art many other scripting languages and specific script commands may be used to implement the invention.

Moreover, the invention is not limited to the specific applications
30 described. The system and method of the invention have many other applications

both inside and outside the healthcare industry. For example, pharmaceutical manufacturers may apply the system in the clinical development and post marketing surveillance of new drugs, using the system as an interactive, on-line monitoring tool for collecting data on the efficacy, side effects, and quality of life impact of the drugs. Compared to the current use of labor-intensive patient interviews, the system provides a fast, flexible, and cost effective alternative for monitoring the use and effects of the drugs.

The system may also be used by home healthcare companies to enhance the service levels provided to customers, e.g. panic systems, sleep surveillance, specific monitoring of disease conditions, etc. Alternatively, the system may be used to monitor and optimize the inventory of home-stationed health supplies. As an example, the system may be connected to an appropriate measuring device to optimize timing of oxygen tank delivery to patients with chronic obstructive pulmonary disease (COPD).

The system and method of the invention also have many applications outside the healthcare industry. For example, the system may be used for remote education over the Internet, facilitating educational communication with children or adult trainees who lack access to sophisticated and expensive computer equipment. The system may also be used by law enforcement officers to perform on-line surveillance of individuals on probation or parole.

Further, the invention has numerous applications for gathering data from remotely located devices. For example, the system may be used to collect data from smart appliances, such as identification check systems. Alternatively, the system may be applied to the remote monitoring of facilities, including safety and security monitoring, or to environmental monitoring, including pollution control and pipeline monitoring. Many other suitable applications of the invention will be apparent to one skilled in the art.

Therefore, the scope of the invention should be determined not by the examples given, but by the appended claims and their legal equivalents.

WO 02/41227

PCT/US01/09046

APPENDIX A



25315

PATENT TRADEMARK OFFICE

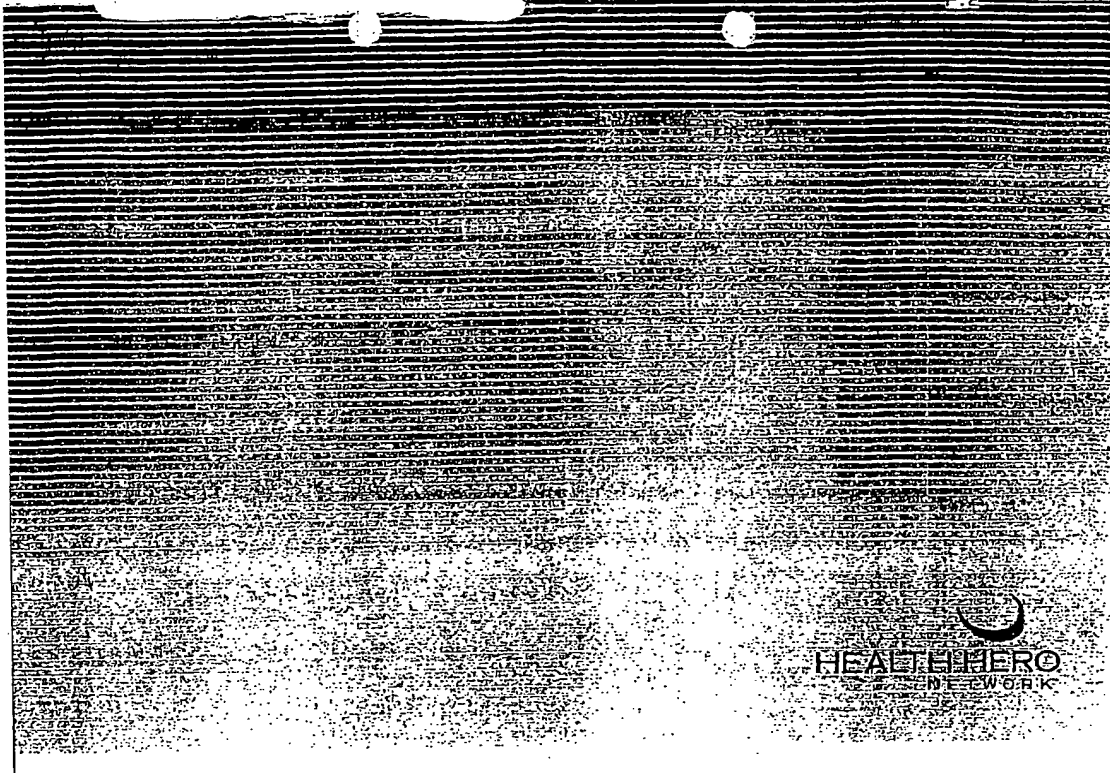

Smoking Cessation Library

Basic Profile



Name:	Basic Profile	Created by:	Jane Hoffmann	Input variables:
Description:	Program intro and basic profiling	Created on:	4/19/99	
Program:	Health Hero Library	Approved by:	Jane Hoffmann	
Protocol:	Smoking Library	Approved on:	4/20/99	
Version:	1	Modified by:	Jane Hoffmann	
Effective on:	4/19/99	Modified on:	10/13/99	

- Welcome <> to the Health Buddy Smoking Information program. This program has been brought to you by Health Hero Network. [Program Intro : None / General]
- Each day I will ask you questions about smoking and will share tips or facts about smoking with you. Remember, Sierra Pacific Power does not have access to your answers. They will only be seen by the Health Buddy care manager. [Intro/ disclaimer : None / General]
- I'd encourage you to share your concerns and facts about your smoking with your doctor. [Intro cont. : None / General]
- How many cigarettes did you smoke in the last 24 hours? [Cigarettes per day : None / General]
 - ➔ 0 to 20
 - ➔ 21 to 40
 - ➔ 41 to 200
- Are you willing to start smoking less? [Willing to smoke less : None / Behavior]
 - ➔ No
 - Too bad! But thanks for being honest! [New Question : None / Behavior]
 - ➔ Yes, by 10 cigarettes a day
 - Great! Smoking less is an important step in quitting. [New Question : None / Behavior]
 - ➔ Yes, by 20 cigarettes a day
 - Great! Smoking less is an important step in quitting. [New Question : None / Behavior]
 - ➔ I don't know
 - OK, keep thinking about it. Smoking less is an important step in quitting. [New Question : None / Behavior]
- <>, what type of cigarettes do you smoke? [Cigarette Type : None / General]
 - ➔ filtered
 - What type of filtered cigarette do you smoke? [filtered type : None / Symptoms]
 - ➔ normal filtered
 - ➔ low tar and low nicotine
 - ➔ non-filtered
 - Would you consider switching to a filtered brand? [New Question : None / Behavior]
 - ➔ Yes
 - Good! Please switch as soon as possible. [New Question : None / Behavior]
 - ➔ No
 - OK, but please keep thinking about it. Perhaps you'll change your mind. [New Question : None / Behavior]
 - ➔ On a scale from 1-5 (with 1 being very little urge and 5 being the strongest urge), how would you rate your strongest urge to smoke on a normal day? [Urge : None / General]
 - ➔ 1 to 2
 - You have very moderate urges to smoke. It is very possible for you to cut down on cigarettes and even to quit! [New Question : None / General]
 - ➔ 3 to 3
 - Even though you have fairly strong urges to smoke, it is possible to cut down and to quit. [New Question : None / General]

Basic Profile

Page 2 of 3

- ➔ 4 to 5
 - Even with such strong urges to smoke, it is possible to cut down and to quit. [New Question : None / General]
- When you feel the urge to smoke ask yourself these questions: [Urge questions : None / General]
 - ➔ What am I doing now?
 - ➔ Where am I?
 - ➔ What am I thinking about?
 - ➔ Who, if anyone, am I with?
- Urges to smoke often come at predictable times. A secret to cutting down or quitting is to know what those urge times are for you and to plan for ways to avoid smoking when the urge hits. [Predictable urges : None / General]
- On a scale from 1-5 (with 1 being very little urge and 5 being the strongest urge), how would you rate your strongest desire to QUIT smoking on a normal day? [Quit Desire : None / General]
 - ➔ 1 to 2
 - ➔ 3 to 3
 - ➔ 4 to 5
- ◁, does anyone in your immediate family smoke? [Family Smoke : None / General]
 - ➔ Yes
 - Have any members of your family ever been told they have emphysema? [Family Emphysema : None / General]
 - ➔ Yes
 - ➔ No
 - Have any members of your family ever been told they have heart disease? [Family Heart Disease : None / General]
 - ➔ Yes
 - ➔ No
 - ➔ No
 - You are fortunate that they don't smoke. See if you can get their support as you cut down or quit. [New Question : None / General]
- ◁, do any of your close friends smoke? [Friends Smoking : None / General]
 - ➔ Yes
 - Sometimes that makes it harder for you to cut down or quit. But you can do it! [New Question : None / General]
 - ➔ No
 - Good! Talk to your friends to get their support as you cut down and quit. [New Question : None / General]
- Do you have any problems with coughing or shortness of breath? [Coughing : None / General]
 - ➔ Yes
 - Be sure to discuss these symptoms with your doctor. [New Question : None / Symptoms]
 - ➔ No
 - As you cut down on your smoking, and especially if you quit, you will probably see an improvement in your coughing and breathing! [Improve coughing : None / Symptoms]
- Have you noticed any tobacco stains on your teeth? [Oral Decay : None / General]
 - ➔ Yes
 - Be sure to make an appointment with your dentist and discuss this. [New Question : None / General]
 - ➔ No
 - You have been lucky about that. Long-time tobacco use often stains teeth. [New Question : None / Symptoms]
- Tobacco use can cause gum disease and other dental problems. You should brush your teeth frequently and see your dentist regularly. [Dental problems : None / General]
- Do you have any problems with your heart or circulation? [Heart disease/circulation : None / General]
 - ➔ Yes
 - Smoking can make heart and circulation problems worse. Be sure to talk to your doctor about this and get your doctor's support as you cut down or quit. [New Question : None / General]

Basic Profile

➔ No

You are fortunate. Smoking can bring on heart and circulation problems and make them worse. [New Question : None / General]

Have you ever had any problems with depression for an extended period of time? [Depression : None / General]

➔ Yes

Be sure to discuss with your doctor your plans to cut down or quit smoking. [New Question : None / General]

➔ No

You should be proud <-> that you're doing this Health Buddy Smoking Information program. It could be the first step to cutting down or quitting smoking! [Feedback : None / General]

Psychomotor Benefits

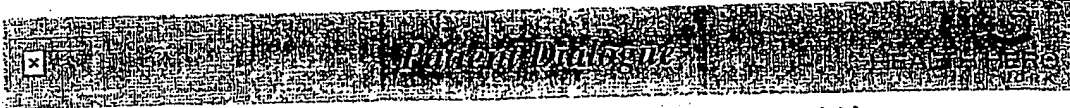

Name:	Psychomotor Benefits	Created by:	Jane Hoffmann	Input variables:
		Created on:	4/21/99	
Description:	Benefits Analysis: Psychomotor	Approved by:	Jane Hoffmann	
		Approved on:	4/21/99	
Program:	Health Hero Library	Modified by:	Jane Hoffmann	
Protocol:	Smoking Library	Modified on:	10/13/99	
Version:	1			
Effective on:	4/21/99			

- Many people really enjoy touching, or playing with cigarettes. Finding a replacement for this activity can make quitting much easier. [Handling cigarettes : None / Behavior]
- Fact of the Day: More than 3 million Americans stop smoking each year! [Daily fact/ 3 million quit : None / General]
- <>, do you enjoy handling cigarettes or do you ever smoke to keep your hands busy? [Busy Hands : None / Behavior]
 - ➔ Yes
 - HINT: Handling something else, such as a pencil or paper clip may help you avoid smoking as many cigarettes. [Hint : None / Behavior]
 - ➔ No
- Do you ever blow smoke rings? [Smoke Rings : None / Behavior]
 - ➔ Yes
 - What would be a good substitute activity? Deep breathing exercises may be a help, breathing slowly in through your nose and out through your mouth. [New Question : None / Behavior]
 - ➔ No
- Do you ever find yourself playing with cigarettes or ashes? [Play : None / Behavior]
 - ➔ Yes
 - HINT: Playing with something else, such as a pen or paper clip, may help you avoid smoking. [New Question : None / Behavior]
 - ➔ No
- Do you have a special way of packing your cigarettes? [Ritual Packing : None / Behavior]
 - ➔ Yes
 - It sounds like you enjoy handling cigarettes. What other activity could you substitute? Perhaps arranging pens or paper clips would be helpful. [Substitute activity : None / Behavior]
 - ➔ No
- Do you find that you spend as much time just holding the cigarette as you do smoking it? [Hold Cigs : None / Behavior]
 - ➔ Yes
 - Think of other things to keep in your hand such as a pen or pencil! [New Question : None / Behavior]
 - ➔ No
 - HINT: Carrying around a soft ball to squeeze may help you keep your hands busy, and make it easier to quit. [Hint : None / Behavior]

Physical Benefits



Name:	Physical Benefits	Created by:	Jane Hoffmann	Input variables:
Description:	Benefits Analysis: Physiological	Created on:	4/20/99	
Program:	Health Hero Library	Approved by:	Jane Hoffmann	
Protocol:	Smoking Library	Approved on:	5/3/99	
Version:	1	Modified by:	Jane Hoffmann	
Effective on:	4/20/99	Modified on:	10/13/99	

- For many people, cigarettes are as addictive as heroin or cocaine. Within seconds of taking a puff of smoke, nicotine travels to the brain. It tells the brain to release chemicals that make you want to smoke more. [Daily Fact : None / General]
- <>, do you believe you are physically addicted to nicotine? [Physical Addiction : None / General]
 - Yes
 - No
- Do you believe that smoking increases your alertness? [Increases Alertness : None / Behavior]
 - Yes
 - No
- Do you tend to smoke first thing in the morning to help get your day going? [Early Morning : None / Behavior]
 - Yes
 - No
- Do you smoke to relax? [Relax : None / Behavior]
 - Yes
 - No
- Healthier ways to relax include meditation, prayer, yoga, and deep breathing exercises. [Other relaxers : None / General]
- Do you smoke to curb your appetite? [Curb Appetite : None / Behavior]
 - Yes
 - No
- Some people find it helps to curb their appetite by drinking a glass of water before a meal, and drinking water throughout the day. It's healthier! [Hint: Drink water : None / General]
- Do you smoke at the end of each meal? [End Of Meal : None / Behavior]
 - Yes
 - No
- Some healthier things to do after a meal are: [Other end of meal activities : None / General]
 - Chew gum.
 - Good idea! [New Question : None / General]
 - Enjoy a mint.
 - Good idea! [New Question : None / General]
 - Brush your teeth.
 - Good idea! Having your mouth feel clean and fresh may make it easier to avoid a cigarette. [New Question : None / General]
 - Sip a cup of coffee.
 - The coffee may be fine, but be sure that coffee doesn't put you in the mood for a cigarette. [New Question : None / General]
- Do you smoke because it helps you keep your weight down? [Weight Fear : None / Behavior]
 - Yes
 - No
- Thank you for continuing with the Health Buddy Smoking Information program! I hope it's helping you to cut down or quit. [Encouragement : None / General]

Physical Benefits

Page 2 of 2

- If you think you may be physically addicted to cigarettes, talk to your doctor about using a nicotine replacement or other medication while you are quitting. [Nicotine replacement : None / Symptoms]
- There are several types of nicotine replacements to discuss with your doctor: Gum, Patches, Inhalers, or Medication. [Types of replacement : None / Knowledge]

Psychological Benefits

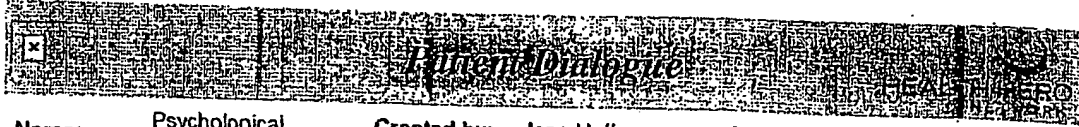

Name: Psychological Benefits **Created by:** Jane Hoffmann **Input variables:**
Description: Benefits Analysis: Psychological **Created on:** 4/20/99
Program: Health Hero Library **Approved by:** Jane Hoffmann
Protocol: Smoking Library **Approved on:** 4/20/99
Version: 1 **Modified by:** Jane Hoffmann
Effective on: 4/20/99 **Modified on:** 10/15/99

- Don't be afraid to talk about how you feel about quitting. Your family, friends and doctor can offer encouragement and support. [Daily Fact : None / General]
- <>, do you like to smoke when you're on the phone? [Smoke on Phone : None / Behavior]
 - ➔ Yes
 - HINT: As you cut down or quit, keep something near the phone, like a squeeze ball, to occupy your hands while you are talking. [New Question : None / General]
 - ➔ No
 - Good for you! [New Question : None / General]
- Do you believe you smoke out of habit? [Out of Habit : None / Behavior]
 - ➔ Yes
 - For most smokers, smoking is a habit. Habits can be broken, but it takes planning! [New Question : None / General]
 - ➔ No
 - Give some serious thought to the reasons that you smoke. Often, it is at least partly out of habit. [New Question : None / General]
- Do you tend to smoke when you are bored? [When Bored : None / Behavior]
 - ➔ Yes
 - If you decide to cut down or quit, it will be important to you to have activities planned during the time you are cutting down. [Response : None / General]
 - ➔ No
- Do you believe cigarettes are your friend? [Cigarettes Are Friends : None / General]
 - ➔ Yes
 - Sometimes cigarettes help people meet emotional needs. As you cut down or quit, you will look for support from the people around you, your family and friends. [New Question : None / General]
 - ➔ No
- Do you find smoking helps alleviate stress? [Alleviate Stress : None / General]
 - ➔ Yes
 - Many people smoke because they think it helps them relieve stress. As you cut down or quit, you will need to identify healthy ways to relieve stress. [New Question : None / General]
 - ➔ No
- Do you ever smoke to change your mood? [Change Mood : None / General]
 - ➔ Yes
 - If you smoke to feel better, as you plan to cut down or quit smoking, you will have to plan healthier ways to change your mood. [New Question : None / General]
 - ➔ No
- Do you smoke in conjunction with certain activities (for example, when you go fishing or shopping)? [Ritual : None / Behavior]
 - ➔ Yes
 - As you cut down or quit smoking it will be important for you to avoid these activities as

Psychological Benefits

Page 2 of 2

much as you can. [New Question : None / General]

No



Name: Psychosocial Benefits **Created by:** Jane Hoffmann **Input variables:**
Description: Benefits Analysis: Psychosocial **Created on:** 4/21/99
Program: Health Hero Library **Approved by:** Jane Hoffmann
Protocol: Smoking Library **Approved on:** 4/21/99
Version: 1 **Modified by:** Jane Hoffmann
Effective on: 4/21/99 **Modified on:** 10/15/99

- Your daily social environment can make it much more difficult to quit. However, there are things that can be done to help overcome these obstacles. [Environment : None / General]
- True or false? Smoking is the single greatest preventable cause of illness and premature death in the United States. [Daily Fact : None / General]
 - ⇒ True
 - You're right! Smoking IS the greatest preventable cause of illness and premature death in the United States. [New Question : None / Knowledge]
 - ⇒ False
 - The answer is true. Smoking IS the greatest preventable cause of illness and premature death in the United States. [New Question : None / Knowledge]
- Do you ever smoke to be social? [Social : None / Behavior]
 - ➔ Yes
 - As you cut down or quit smoking, you will find new ways to be social that don't involve smoking. [New Question : None / General]
 - ⇒ No
 - Good. That's not a good reason for smoking! [New Question : None / General]
- Do you smoke with your friends? [Friends Smoke : None / Behavior]
 - ➔ Yes
 - As you cut down or quit, it will be important for you to tell your friends what you are doing so they can support you. [New Question : None / General]
 - ⇒ No
- Do you mainly smoke when people around you are smoking? [Smoke with Others : None / Behavior]
 - ➔ Yes
 - As you cut down or quit smoking, it may important for a while to avoid your friends when they are smoking. [New Question : None / General]
 - ⇒ No
- Do you smoke to assert your independence? [Independence : None / General]
 - ➔ Yes
 - Remember that quitting is a choice. There are many benefits from smoking, but also many risks. Your participation in this program indicates that you believe that the risks outweigh the benefits. [Rebel : None / General]
 - ⇒ No
 - Good for you! [New Question : None / General]

Motivators

Page 1 of 2



Name: Motivators **Created by:** Jane Hoffmann **Input variables:**
Description: Motivational analysis **Created on:** 4/21/99
Program: Health Hero Library **Approved by:** Jane Hoffmann
Protocol: Smoking Library **Approved on:** 4/21/99
Version: 1 **Modified by:** Jane Hoffmann
Effective on: 4/21/99 **Modified on:** 10/13/99

- Smoking Fact: Secondhand smoke is responsible for 150,000 to 300,000 respiratory infections a year in children. [Daily Fact : None / General]
- Is your decision to quit based in part on a desire to live longer? [Longevity : None / Knowledge]
 - ➔ Yes
 - ➔ No
- True or false: On the average, smokers die 5 years earlier than non-smokers. [Mortality fact : None / Knowledge]
 - ➔ True
 - Actually it's worse than that! On the average, smokers die an average of 7 years earlier than non-smokers! [New Question : None / Knowledge]
 - ➔ False
 - You're right. It's worse than that! On the average, smokers die an average of 7 years earlier than non-smokers! [New Question : None / Knowledge]
- Is one of the reasons you want to cut down or quit smoking, a desire to be healthier? [Healthier : None / Knowledge]
 - ➔ Yes
 - Great! You will be healthier when you cut down and especially when you quit. [New Question : None / General]
 - ➔ No
 - OK, but you will be healthier when you cut down and especially when you quit. [New Question : None / General]
- Has smoking inhibited your ability to enjoy life? [Enjoyment : None / General]
 - ➔ Yes
 - I think you will enjoy life even more if you quit smoking! [New Question : None / General]
 - ➔ No
 - I think you will enjoy life even more if you quit smoking! [New Question : None / General]
- Are you trying to cut down or quit to gain better control over your life? [Control : None / General]
 - ➔ Yes
 - You will feel more in control of your life when you cut down, and especially if you quit! [New Question : None / General]
 - ➔ No
 - Even so, you will feel more in control of your life when you cut down, and especially if you quit! [New Question : None / General]
- Has your family played a significant role in your decision to quit smoking? [Family : None / General]
 - ➔ Yes
 - Good. Family can be a great support while you are cutting down or quitting. [New Question : None / General]
 - ➔ No
 - When you've decided to cut down or quit, be sure to discuss it with your family. They can be a great help to you. [New Question : None / General]
- Did a fear of affecting those around you with secondhand smoke, influence your decision to quit? [Secondhand : None / General]

Motivators

Page 2 of 2

- ➔ Yes
 - Good. That's a serious issue. Secondhand smoke is very harmful to those around you, especially to children. [New Question : None / General]
- ➔ No
 - OK, but it is something to consider. Secondhand smoke is very harmful to those around you, especially to children. [New Question : None / General]
- Did wanting to fit in with non-smokers affect your decision to quit? [Acceptance : None / General]
 - ➔ Yes
 - OK. I imagine that your non-smoking friends will be happy when you smoke less or quit. [New Question : None / General]
 - ➔ No
 - OK. But I imagine that your non-smoking friends will be happy when you smoke less or quit. [New Question : None / General]
- Did your friends who don't smoke, influence your decision to quit? [Friends : None / General]
 - ➔ Yes
 - OK, but the decision must be yours! [New Question : None / General]
 - ➔ No
 - OK. The decision is yours to make. [New Question : None / General]
- Did you decide to quit in part because you are concerned about how smoking impacts the environment? [Environment : None / General]
 - ➔ Yes
 - OK! Smoking is harmful to the environment as well as harmful to you! [New Question : None / General]
 - ➔ No
 - Smoking is harmful to the environment as well as harmful to you! [New Question : None / General]
- Is the money you'll save by not smoking, impacting your decision to quit? [Economic : None / General]
 - ➔ Yes
 - You will save a lot of money as you cut down and quit! [New Question : None / General]
 - ➔ No
 - You will save a lot of money as you cut down and quit! [New Question : None / General]
- When you have decided to cut down on your smoking or to quit entirely, it is a great idea to plan to reward yourself after a certain number of successful days or weeks. [Rewards : None / General]
- A good reward would be: [Good rewards : None / General]
 - ➔ A box of fine cigars.
 - Not exactly. Don't reward yourself with tobacco! You are trying to smoke less. Plan a reward that is something else you would enjoy. [New Question : None / General]
 - ➔ Dinner at a special restaurant.
 - Good. A reward should be something you would enjoy! [New Question : None / General]
 - ➔ A shirt you've been wanting.
 - Good. A reward should be something you would enjoy! [New Question : None / General]
- Some people save the money that they would have spent on cigarettes, and use it to buy something special for someone else, or give it to their favorite charity. [Reward hint : None / General]
- Is your career influencing your decision to quit? [Career : None / General]
 - ➔ Yes
 - Things may be easier at work when you don't have to duck out for smoke breaks! [New Question : None / General]
 - ➔ No
 - Things may be easier at work when you don't have to duck out for smoke breaks! [New Question : None / General]



Name:	Benefits Analysis	Created by:	Jane Hoffmann	Input variables:
Description:	Benefits Analysis: Conclusion	Created on:	4/21/99	
Program:	Health Hero Library	Approved by:	Jane Hoffmann	
Protocol:	Smoking Library	Approved on:	4/26/99	
Version:	1	Modified by:	Jane Hoffmann	
Effective on:	4/21/99	Modified on:	10/13/99	

- By taking an initial small step toward quitting, you will confirm your commitment, and increase your chances of success. [Intro2 : None / General]
- HINT: The first step is to commit to begin smoking less. How many cigarettes did you smoke in the last 24 hours? [Hint : None / General]
 - ⇒ 0 to 20
 - ⇒ 21 to 40
 - ⇒ 41 to 200
- Are you willing to smoke less? [Commit : None / General]
 - ⇒ Yes
 - ⇒ No

Attitude Assessment



Name: Attitude Assessment **Created by:** Jane Hoffmann **Input variables:**
Description: Smoking phase 1 **Created on:** 4/27/99
Program: Health Hero Library **Approved by:** Jane Hoffmann
Protocol: Smoking Library **Approved on:** 4/27/99
Version: 1 **Modified by:** Jane Hoffmann
Effective on: 4/27/99 **Modified on:** 10/15/99

- Here is an interesting smoking fact: There are 401 poisons and 43 carcinogens in each cigarette. [Daily Fact : None / General]
- <>, have you made any changes to your daily routine to help you reduce the number of cigarettes you smoke, or to help you quit? [Changes in routine : None / Behavior]
 - ⇒ Yes
 - That's fantastic! It's an important part of committing to becoming smoke-free. Keep up the great work! [Good/follow-up : None / General]
 - ⇒ No
 - That's OK. By making simple changes to your daily routine, you can avoid situations in which you are prone to smoke. This will make cutting down or quitting much easier. [Not change/follow-up : None / General]
- On a scale of 1-5 (with 1 being not confident and 5 being very confident) how confident are you that you are capable of quitting? [Self efficacy : None / General]
 - ⇒ 1 to 2
 - Is your hesitation caused by not feeling like you know enough about what's required to successfully quit? [Cause of hesitation : None / General]
 - ⇒ Yes
 - That's OK. I will continue to give you more helpful information about cutting down and quitting. Near the end of this program, I will give you information on other resources that may be helpful to you. [New Question : None / General]
 - ⇒ No
 - Is your hesitation caused by not feeling that you have the skills necessary to successfully quit? [New Question : None / General]
 - ⇒ Yes
 - That's OK. I will continue to give you more helpful information about skills for cutting down and quitting. Near the end of this program, I will give you information on other resources that may provide you with additional skills. [New Question : None / General]
 - ⇒ No
 - Is your hesitation caused by feeling that you do not have the power to successfully cut down or quit smoking? [New Question : None / General]
 - ⇒ Yes
 - That's OK. Participating in this program is a great first step. Near the end of this program, I will give you information on more resources that could help you cut down or quit. I know you can do it! [New Question : None / General]
 - ⇒ No
 - Thanks for sticking with this Health Buddy program. I hope it helps you gain confidence in your ability to cut down or quit. I know you can do it! [New Question : None / General]

Attitude Assessment

Page 2 of 2

- ⇒ 3 to 4
- Great! I hope that following this Health Buddy program and following some of the hints and suggestions will increase your confidence. I know you can do it! [New Question : None / General]
- ⇒ 5 to 5
- Terrific! You have the confidence to do it. Good for you! [New Question : None / General]
- Do you believe that smoking is a choice? [Choice : None / General]
- ⇒ Yes
- That's right. Smoking is a choice. [New Question : None / General]
- ⇒ No
- Why do you believe smoking isn't a choice? [Why not a choice? : None / General]
- ⇒ I can't help it.
- It is sometimes very difficult to stop smoking, but it can be done. It is a choice that you have. [New Question : None / General]
- ⇒ I've always done it.
- It is sometimes very difficult to stop smoking, especially when you have smoked for a long time, but it can be done. It is a choice that you have. [New Question : None / General]
- ⇒ All of my friends smoke.
- It is sometimes very difficult to stop smoking, especially when many of your friends smoke, but it can be done. It is a choice that you have. [New Question : None / General]
- By participating in this Health Buddy program, you have made a choice to cut down or to quit smoking. No matter how strong your craving for a cigarette becomes, remember that it's still a choice. [Participating in program : None / General]
- Do you believe that smoking has an ill affect on your health? [Affect on health : None / General]
- ⇒ Yes
- That's right. Unfortunately, smoking has a detrimental impact on health. [New Question : None / General]
- ⇒ No
- Unfortunately, smoking has a detrimental impact on health. [New Question : None / General]
- Do you believe that quitting will make your life better? [Quitting improves life : None / General]
- ⇒ Yes
- That's a great attitude! [New Question : None / General]
- ⇒ No
- I'm sorry to hear that. I think that the facts and information I'm sharing with you show that you life will be better without smoking! [New Question : None / General]

Hints for cutting down

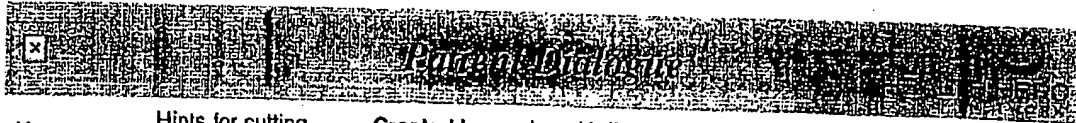

Name:	Hints for cutting down	Created by:	Jane Hoffmann	Input variables:
Description:	Hints for cutting down	Created on:	6/28/99	
Program:	Health Hero Library	Approved by:	Jane Hoffmann	
Protocol:	Smoking Library	Approved on:	6/28/99	
Version:	1	Modified by:	Jane Hoffmann	
Effective on:	6/28/99	Modified on:	10/13/99	

- When you are trying to cut down or quit smoking, it sometimes is helpful to put something else in your mouth to chew on. Good things to chew on are: gum, mints, or carrots or celery sticks. [Substitution : None / General]
- As you are cutting down on cigarettes, it is helpful to increase your activities. [Activities : None / General]
- Some of the activities that it would be helpful to increase are: [Activities cont. : None / General]
 - ⇒ Taking walks
 - Good. It is great to become more physically active while cutting down. [New Question : None / General]
 - ⇒ Swimming
 - Good. It is great to become more physically active while cutting down. [New Question : None / General]
 - ⇒ Watching television
 - Not exactly. It is important to become more physically active while cutting down. [New Question : None / General]
- While cutting down or quitting, it is helpful to keep your hands busy, especially during times you would ordinarily smoke. Some activities that keep your hands involved are craft work, house work, and using a computer. [Busy hands : None / General]
- When you are cutting down on cigarettes, avoid the places where you usually smoke. If you have a favorite "smoking chair" at home or at work, sit somewhere else. [Where do you smoke : None / General]
- When you have the urge to smoke, try to postpone lighting up. See how long you can put it off. Five minutes? Half an hour? Longer? Any delay is a good delay. [Postponing cigarette : None / General]
- Which of these activities might help you postpone or avoid a cigarette? [Activities to help postpone : None / General]
 - ⇒ Taking a shower
 - Great idea! It's hard to smoke in the shower. [New Question : None / General]
 - ⇒ Brushing your teeth
 - Some people find it very helpful to brush their teeth whenever they feel the urge to smoke. It's good for your teeth too! [New Question : None / General]
 - ⇒ Drinking a glass of water or juice
 - Sometimes a glass of water or juice helps people avoid the next cigarette. Try it. [New Question : None / General]
- HINT: Don't empty your ashtrays for a week. Take time to look at the dirt and the ashes from your cigarettes. [Don't empty ashtray : None / General]
- When you are cutting down, don't buy cigarettes by the carton. It will be more inconvenient and expensive to go out and buy each pack. [Don't buy carton : None / General]
- Decide that for a week, you will hold your cigarette in the opposite hand. If you are right-handed, use your left hand. This will make smoking less comfortable. [Use other hand : None / General]
- Don't carry cigarettes with you. This will make it very inconvenient to smoke away from home. [Don't carry cigarettes : None / General]
- While you are cutting down on the number of cigarettes that you smoke, try smoking just half of each

Hints for cutting down

Page 2 of 2

- cigarette. [Smoking half cigarettes : None / General]
- When you wake up in the morning, try postponing your first cigarette by 1 hour the first day, 2 hours the second day, and so on. [Postpone first cigarette of day : None / General]
 - Create a "looking glass jar". Collect all of your cigarette butts in a clear glass jar. When you are tempted to light up, look at the jar. See the ashes and fillth, and think again. [Looking glass jar : None / General]
 - Some people find it helpful to hold something else in their mouth while they are trying to cut down or quit cigarettes. [Something else in mouth : None / General]
 - Which of these are good things to hold in your mouth? [Something else in mouth, cont. : None / General]
 - ⇒ A toothpick
 - Good idea! [New Question : None / Behavior]
 - ⇒ A pacifier
 - OK, if you don't mind the teasing. [New Question : None / Behavior]
 - ⇒ An unlit cigarette
 - Not a good idea! It's too tempting just to light up. [New Question : None / Behavior]
 - ⇒ A pen
 - OK. Have another one to write with! [New Question : None / Behavior]
 - When you are deciding to cut down on the number of cigarettes you will smoke each day, it may be helpful to write down the number and post it. [Write down the number : None / General]
 - A good place to post the number of cigarettes you've decided on is: [Post the number : None / General]
 - ⇒ Put it up on the refrigerator.
 - Good idea! Keep the number where you can see it often! [New Question : None / General]
 - ⇒ Put it on your mirror, so you see it every morning.
 - Good idea! Keep the number where you can see it often! [New Question : None / General]
 - ⇒ Hide it under the mattress.
 - Not quite! Keep the number where you can see it often, maybe on the refrigerator or on your mirror. [New Question : None / General]
 - Each evening, set aside only the number of cigarettes you will smoke the following day. Put all the other cigarettes away. Only smoke the ones you have set aside. [Set aside : None / General]
 - While you are cutting back or quitting, it is important to avoid beverages that you usually associate with smoking. It is especially important to avoid alcoholic beverages. It's easier to be tempted to smoke after you drink alcohol. [Beverages to avoid : None / General]
 - One idea that has helped people cut down on the number of cigarettes they smoke, is to switch to a brand they don't like as much. [Switch brands : None / General]
 - Which is a type of cigarettes that you don't like as much as your favorite brand? [Switch brands, cont. : None / General]
 - ⇒ Menthol
 - ⇒ Non-menthol
 - ⇒ Any other brand
 - ⇒ I like them all
 - If you like to smoke while driving, plan a substitute activity for those times you must be in a car. [While driving : None / General]
 - Which of these activities might work for you while you're driving? [While driving, cont. : None / General]
 - ⇒ Chewing gum
 - Good idea! [New Question : None / General]
 - ⇒ Singing
 - That's good, as long as it's okay with your passengers! [New Question : None / General]
 - ⇒ Drinking soda
 - OK! Drink carefully and don't spill. [New Question : None / General]

Hints for quitting

Page 1 of 2

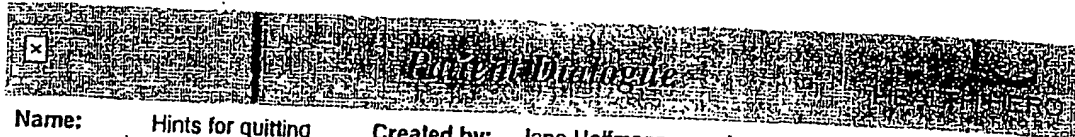

Name: Hints for quitting **Created by:** Jane Hoffmann **Input variables:**
Description: Hints for quitting **Created on:** 6/28/99
Program: Health Hero Library **Approved by:** Jane Hoffmann
Protocol: Smoking Library **Approved on:** 6/28/99
Version: 1 **Modified by:** Jane Hoffmann
Effective on: 6/28/99 **Modified on:** 10/15/99

- Remember that even though you have decided to quit, you will still be tempted. It's a good idea to keep a list of hints and ideas to help you avoid temptation. [Temptation : None / General]
- If you've decided to quit (congratulations!) it is important to look ahead and set your "quit date." [Setting a quit date : None / General]
- Which of these dates might be a good "quit date" for you? [Good quit dates : None / General]
 - ⇒ New Year's Day
 - This a great day for some people to quit--starting the new year right! [New Question : None / General]
 - ⇒ The Great American Smokeout
 - This is a good time to quit. The Great American Smokeout is always the Thursday before Thanksgiving. [New Question : None / General]
 - ⇒ Your birthday
 - Quitting is a great way to start another year of life! [New Question : None / General]
 - ⇒ During the Christmas holidays
 - The holidays may not be a great time to try to quit. There are lots of temptations during the holidays, and they may be a stressful time for some people. [New Question : None / General]
- There are some things that are helpful to do as you prepare to quit. Begin eating a healthier diet. You will feel better and that will help you as you stop smoking. [Before your quit date : None / General]
- Another helpful thing to do before you quit is to have your clothes cleaned to get rid of the tobacco smoke odor. You might also get your drapes and carpets cleaned to get rid of the tobacco odor. [Before you quit, cont. : None / General]
- While you are quitting, it is helpful to drink increased amounts of water. Avoid drinks that you associate with smoking, such as coffee and alcoholic beverages. [Increase water : None / General]
- Think of the great example you set for young people when you quit smoking and remain smoke-free! [Example : None / General]
- Make a list of the reasons you want to quit smoking. Take the time to write these reasons down on paper. Some things to include are: [Reasons to quit : None / General]
 - ⇒ Personal reasons
 - Personal reasons include your health and concerns about your family. [New Question : None / General]
 - ⇒ Time reasons
 - Time reasons include the time you will save by not smoking cigarettes. [New Question : None / General]
 - ⇒ Money reasons
 - Money reasons include figuring out how much money you will save by not smoking for a week, a month, and a year. [New Question : None / General]
- Remember that withdrawal symptoms (if you have any) are temporary. They are strongest during the first week. [Withdrawal symptoms : None / General]
- Most relapses occur during the first week of quitting. Take it day by day. If you do have a relapse, don't give up! Try again! [Relapses : None / General]
- Remember: Don't think of never smoking again. Think of one day at a time. [One day at a time : None / General]
- On the day you quit, keep very busy. Plan activities, get exercise, and keep your hands busy.

Hints for quitting

Page 2 of 2

[Quitting day : None / General]

In the days after you quit, spend as much time as possible in places where smoking isn't even allowed. [Days after quitting : None / General]

After you've quit, don't ever think that one little cigarette won't hurt. It will. [One cigarette will hurt : None / General]

During the time you're quitting, be sure to take especially good care of yourself. Get plenty of rest and pay special attention to your appearance. [Taking care of self : None / General]

Quitting doesn't mean you will automatically gain weight. When people gain weight after quitting, it's because they eat more. [Weight gain : None / General]

What are some good tips to help you avoid weight gain after you've quit smoking? [Tips to avoid weight gain : None / General]

⇒ Drink a glass of water before meals.

Right! Chewing sugarless gum and exercising are also good things to do. [New Question : None / General]

⇒ Chew sugarless gum.

Right! Drinking water before meals and exercising are also good things to do. [New Question : None / General]

⇒ Eat a lollipop instead of smoking.

While an occasional lollipop probably won't hurt, better ideas are to drink water before meals, chew sugarless gum, and exercise more. [New Question : None / General]

⇒ Get involved with exercise.

Right. Drinking water before meals and chewing sugarless gum are also great ideas. [New Question : None / General]

Think about your first month anniversary of not smoking. Plan a special celebration! What will it be? [Anniversary celebration : None / General]

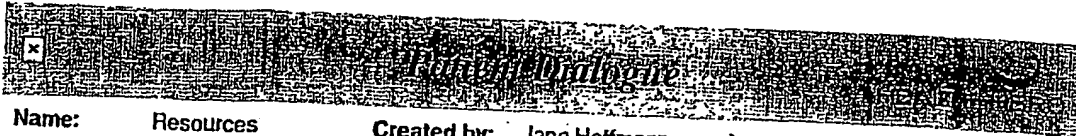

Name: Resources	Created by: Jane Hoffmann	Input variables:
Description: Resources	Created on: 6/29/99	
Program: Health Hero Library	Approved by: Jane Hoffmann	
Protocol: Smoking Library	Approved on: 6/29/99	
Version: 1	Modified by: Jane Hoffmann	
Effective on: 6/29/99	Modified on: 10/7/99	

- There are many organizations which can provide you with information to help you quit smoking. One of them is the Cancer Information Service, part of the National Cancer Institute. [Cancer info svcs : None / General]
- They can provide you with free written materials and give you information about support groups. Make a note of their number: 1-800-4-CANCER (1-800-422-6237). [Cancer info svcs, cont. : None / General]
- Which of the following organizations can help you with information to help you quit smoking? [Other resources : None / General]
 - ⇒ American Cancer Society
 - You're right. All of these organizations can give you information about quitting smoking. Find their phone numbers in your local directory. [New Question : None / General]
 - ⇒ American Heart Association
 - You're right. All of these organizations can give you information about quitting smoking. Find their phone numbers in your local directory. [New Question : None / General]
 - ⇒ American Lung Association
 - You're right. All of these organizations can give you information about quitting smoking. Find their phone numbers in your local directory. [New Question : None / General]
 - ⇒ Saint Mary's Health Promotion Center
 - Yes! Call (775) 789- DOCS (3627) and get enrolled in the Smokeless Program today! [Saint Mary's follow-up : None / General]
 - ⇒ All of the above
 - Yes, any one of these organizations can help you to quit smoking. Call today, they are here to support you <>! [resources follow-up : None / General]

CLAIMS

1. A system for remotely monitoring an individual, the system
5 comprising:
a server;
a remote apparatus for interacting with the individual, the remote
apparatus being in communication with the server via a communication network;
wherein said server comprises:
10 a script generator for generating a script program from a set of
queries and sending the script program to the server, the script program being
executable by the remote apparatus to communicate the set of queries to the
individual, to receive responses to the set of queries, and to transmit the responses
15 from the remote apparatus to the server over the communication network, the
script generator being in communication with the server via the communication
network; and
a database accessible by the script generator, the database capable
of storing the script program and the responses to the set of queries;
and wherein the remote apparatus comprises:
20 a communication component for receiving the script program from
the server and for transmitting the responses to the server;
a user interface; and
a processor connected to the communication component, the user
interface, and the database for executing the script program to communicate the
25 set of queries to the individual, to receive the responses to the set of queries from
the user interface, and to transmit the responses to the server.
2. The system of Claim 1, wherein the user interface comprises a
30 display for displaying the queries, and user input buttons for entering the
responses.

3. The system of Claim 1, wherein the user interface includes a speech synthesis component for audibly communicating the set of queries to the individual.

5

4. The system of Claim 1, wherein the user interface includes a speech recognition component for receiving spoken responses to the set of queries.

10

5. The system of Claim 1, further comprising at least one monitoring device for producing measurements of a physiological condition of the individual and for transmitting the measurements to the remote apparatus, wherein the remote apparatus further includes a device interface component connected to the processor for receiving the measurements from the monitoring device, the measurements are stored in the database, and the communication component transmits the measurements to the server.

15

6. The system of Claim 5, wherein the device interface component includes an interface component with a plurality of monitoring devices, and the script program specifies a selected one of the plurality of monitoring devices from which to collect the measurements.

20

7. The system of Claim 5, wherein the server further comprises a report component for displaying the responses and the measurements on a remote interface device.

25

8. The system of Claim 1, wherein the communication component includes a first establishing component for establishing a first communication link to the server to receive the script program and a second establishing component for establishing a subsequent communication link to the server to

30

transmit the responses, and wherein the script program specifies a connection time at which to establish the subsequent communication link.

5 9. The system of Claim 1, wherein the remote apparatus further comprises a notification component connected to the processor, the notification component for notifying the individual that unanswered queries are stored in the remote apparatus.

10 10. The system of Claim 9, wherein the notification component comprises a visual indicator for visually notifying the individual.

 11. The system of Claim 9, wherein the notification component comprises a display for displaying a prompt.

15 12. The system of Claim 1, further comprising a plurality of remote apparatuses in communication with the server, the plurality of remote apparatuses for remotely monitoring a corresponding plurality of individuals, wherein the database includes a multiple storing component for storing a plurality of script programs, a script entering component for entering script assignment information,
20 the server includes a script assignment component connected to the database for assigning to each of the plurality of individuals at least one of the plurality of script programs in accordance with the script assignment information, and the database further includes a list storing component for storing a list of the plurality
25 of individuals, and for each of the plurality of individuals, a respective pointer to the at least one of the plurality of script programs assigned to each of the plurality of individuals.

 13. A system for remotely interacting with an individual, the system comprising:

30 a) a server;

b) a remote apparatus for interacting with the individual, the remote apparatus being in communication with the server via a communication network; and

5 c) a digital broadcaster in communication with said server and said remote apparatus;

wherein said server comprises:

a script generating component for generating a script program, the script program being executable by the remote apparatus, to receive responses from the individual, and to transmit the responses from the remote apparatus to the
10 server over the communication network; and

a database connected to the script generating component, the database for storing the script program and the responses from the individual;

wherein the digital broadcaster receives a broadcast selection from said remote apparatus and the script program from said server, determines program
15 content according to said broadcast selection, combines said script program with said determined program content to create a digital broadcast program and transmits said broadcast program;

wherein the remote apparatus comprises:

i) a communication component for receiving the broadcast program
20 and for transmitting the responses to the script program to the server;

ii) a user interface for presenting the script program to the individual and for receiving the responses from the individual;

iii) a memory for storing the script program and the responses; and

iv) a processor connected to the communication component, the
25 user interface and the memory for processing the broadcast program and presenting the script program and the broadcast content according to said processing, executing the script program, to receive the responses to the set of queries, and to transmit the responses to the server.

14. The system of Claim 14, wherein the broadcast program is transmitted over a cable link.

5 15. The system of Claim 13, wherein the broadcast program is transmitted over a satellite link.

16. The system of Claim 13, wherein the script generating and the database of the server are distributed over the communications network.

10 17. The system of Claim 13, wherein the program content is entertainment content.

18. The system of Claim 13, wherein the program content is advertisement content.

15 19. The system of Claim 13, wherein the user interface comprises a display.

20 20. The system of Claim 19, wherein the processor determines if a script program is included in the broadcast program and presents an icon on the display indicating a script program is included in the broadcast program.

25 21. The system of Claim 13, wherein the script program is a report generated in accordance with the responses from the individual and said report is transmitted to at least one of a health care professional or the individual.

22. The system of Claim 13, wherein the communications network is a public data network.

30

1/19

Fig. 1

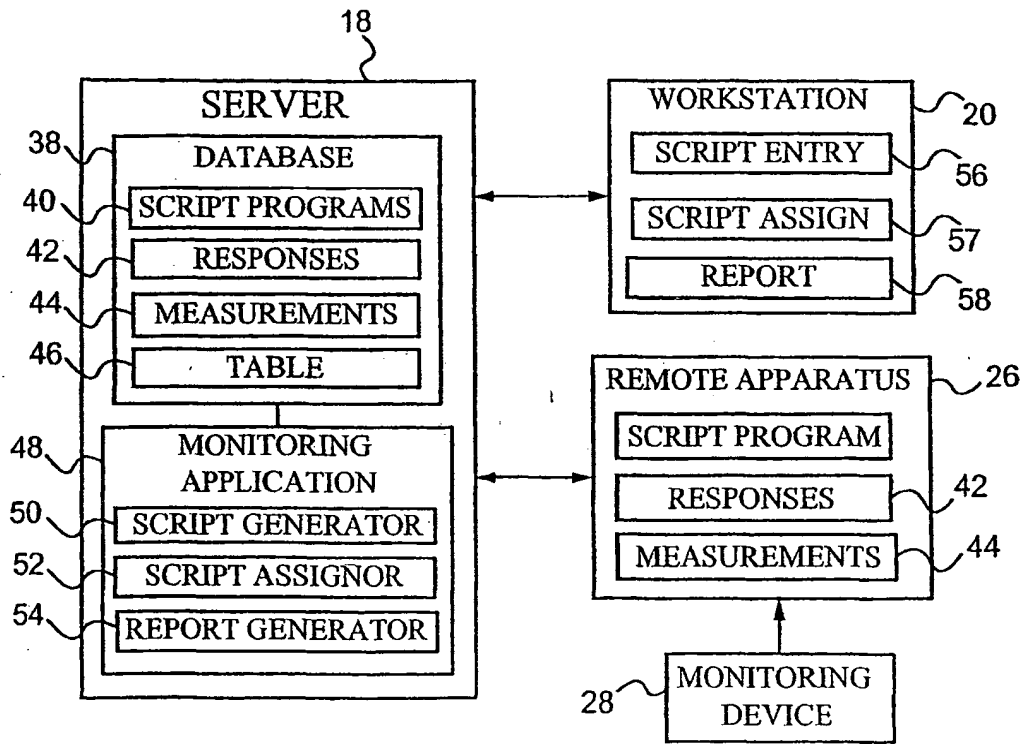
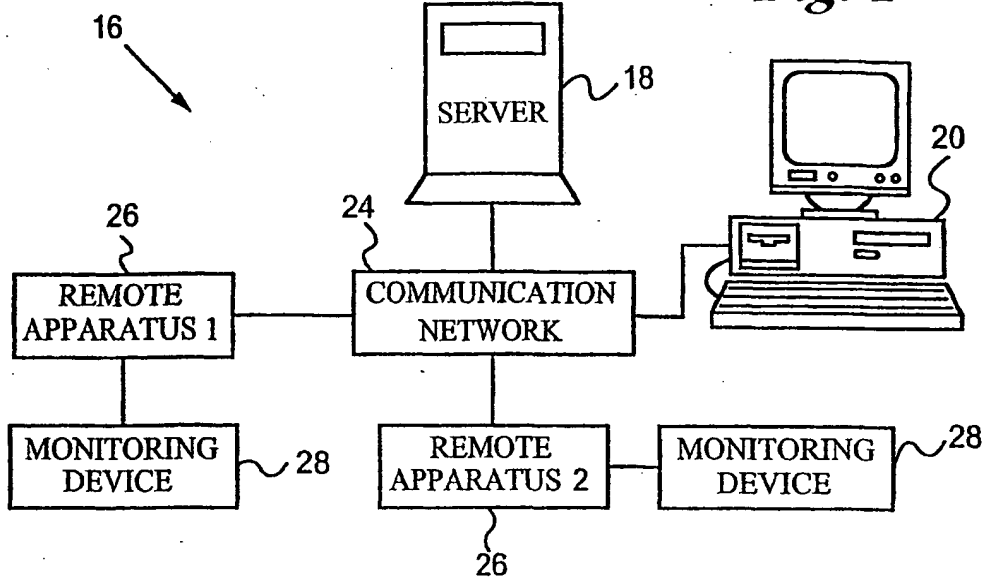

Fig. 2

2/19

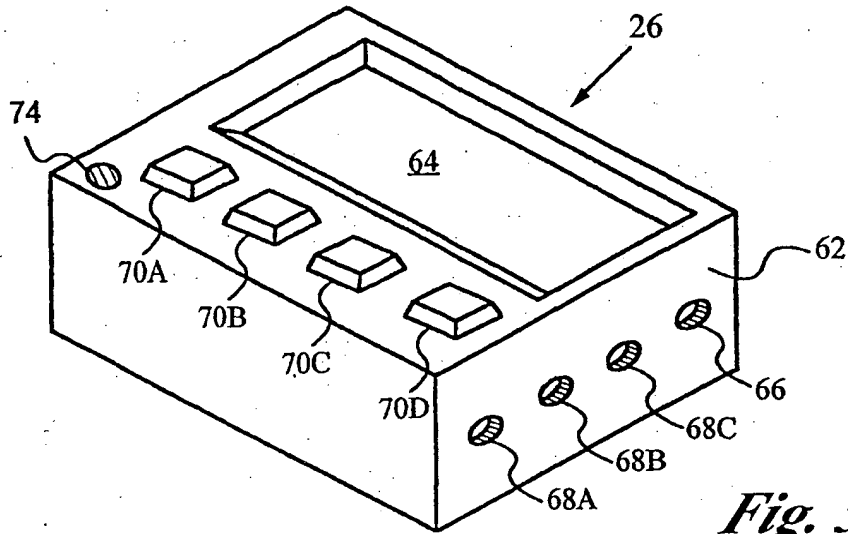

Fig. 3

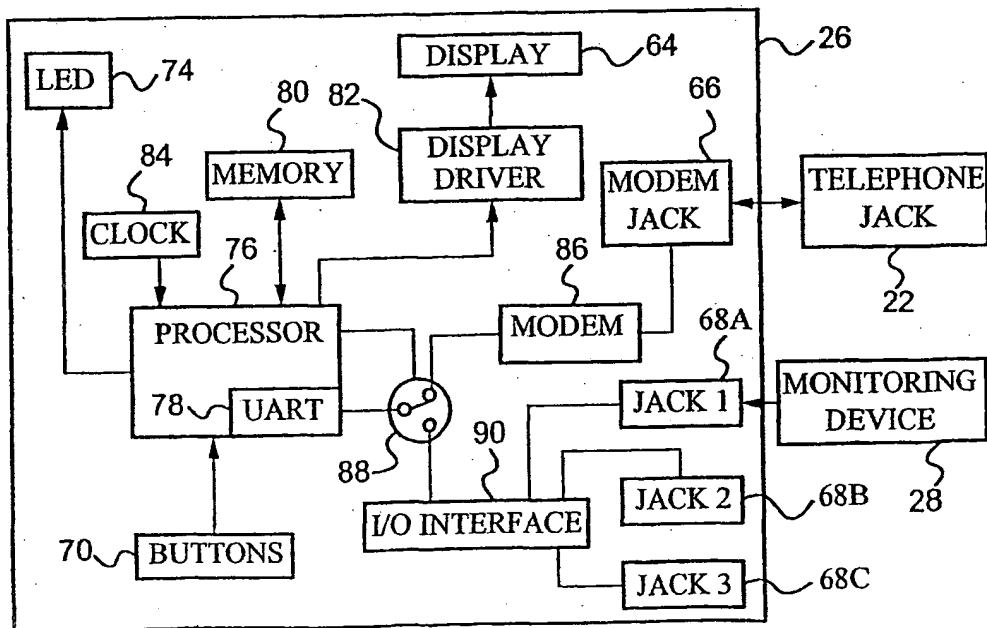

Fig. 4

56

SCRIPT ENTRY SCREEN

SCRIPT NAME: 92

QUERIES

	CHOICE 1	CHOICE 2	CHOICE 3	CHOICE 4
94 HOW DO YOU FEEL?	VERY BAD	BAD	GOOD	VERY GOOD
HOW WELL ARE YOU MANAGING YOUR DISEASE?	VERY BADLY	BADLY	WELL	VERY WELL
HOW HARD IS IT FOR YOU TO FOLLOW YOUR TREATMENT PLAN?	VERY HARD	HARD	EASY	VERY EASY
HOW HARD IS IT FOR YOU TO CONTROL YOUR BLOOD SUGAR?	VERY HARD	HARD	EASY	VERY EASY

96

SELECT DEVICE TYPE(S)

98 GLUCOSE METER RESPIRATORY FLOW METER BP CUFF

CONNECTION TIME: 100 102 104

Fig. 5

4/19

NUMBER: 9001 {LF}

LED: 1 {LF}

ZAP: {LF}

CLS: {LF}

DISPLAY: ANSWER QUERIES NOW?
PRESS ANY BUTTON TO START {LF}

WAIT: {LF}

CLS: {LF}

DISPLAY: HOW DO YOU FEEL?

VERY VERY
BAD BAD GOOD GOOD {LF}

INPUT: 0000 {LF}

CLS: {LF}

DISPLAY: HOW WELL ARE YOU
MANAGING YOUR DISEASE?
VERY VERY
WELL BADLY WELL WELL {LF}

INPUT: 0000 {LF}

CLS: {LF}

DISPLAY: HOW HARD IS IT FOR YOU TO
FOLLOW YOUR TREATMENT PLAN?
VERY VERY
HARD HARD EASY EASY {LF}

INPUT: 0000 {LF}

CLS: {LF}

DISPLAY: HOW HARD IS IT FOR YOU TO
CONTROL YOUR BLOOD SUGAR?
VERY VERY
HARD HARD EASY EASY {LF}*Fig. 6A*

5/19

INPUT: OOOO {LF}
CLS: {LF}
DISPLAY: CONNECT GLUCOSE METER
AND PRESS ANY BUTTON
WHEN FINISHED {LF}
WAIT: {LF}
CLS: {LF}
DISPLAY: COLLECTING MEASUREMENTS {LF}
COLLECT: GLUCOSE_METER {LF}
CLS: {LF}
DISPLAY: CONNECT APPARATUS TO
TELEPHONE JACK AND
PRESS ANY BUTTON
WHEN FINISHED {LF}
WAIT: {LF}
LED: 0 {LF}
CLS: {LF}
DELAY: 03:00 {LF}
DISPLAY: CONNECTING TO SERVER {LF}
CONNECT: {LF}
{EOF}

Fig. 6B

6/19

57

Fig. 7

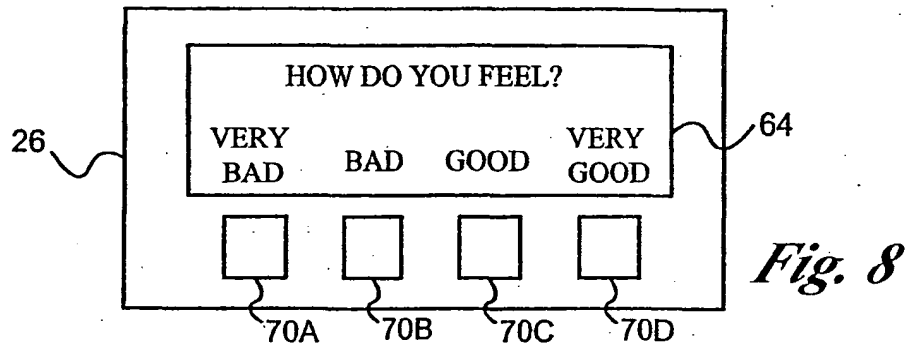
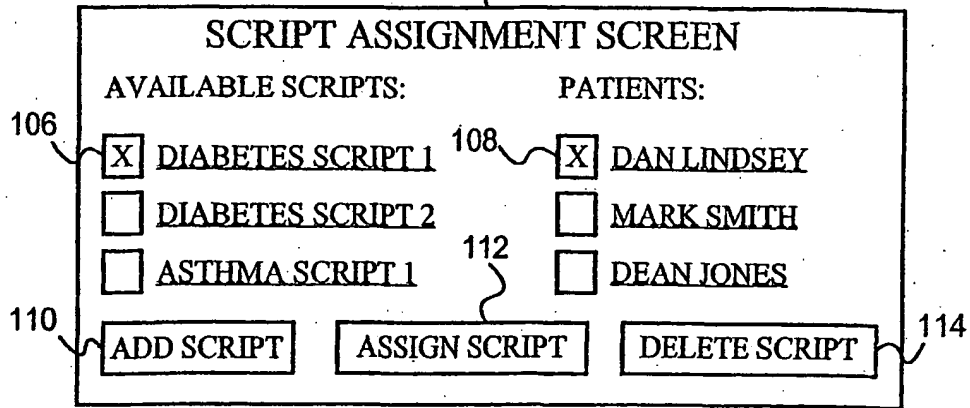

Fig. 8

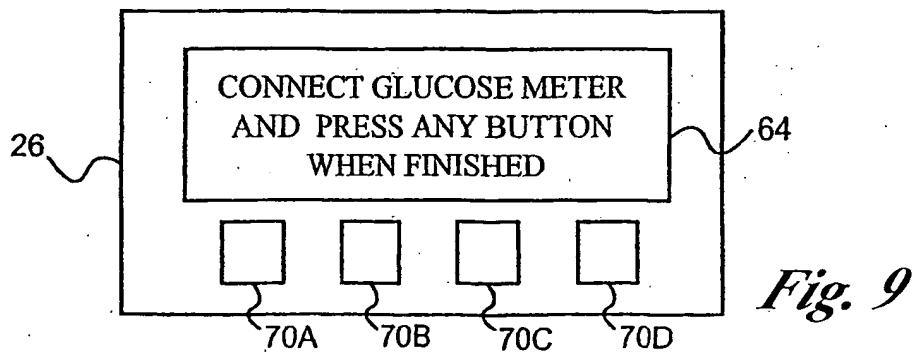

Fig. 9

7/19

58

PATIENT REPORT

PATIENT: LINDSEY, DAN

DATE OF MEASUREMENT: MARCH 15, 1997

42

116

QUERY RESPONSES

HOW DO YOU FEEL?

BAD

HOW WELL ARE YOU MANAGING YOUR DISEASE?

BADLY

HOW HARD IS IT FOR YOU TO FOLLOW YOUR TREATMENT PLAN?

HARD

HOW HARD IS IT FOR YOU TO CONTROL YOUR BLOOD SUGAR?

VERY HARD

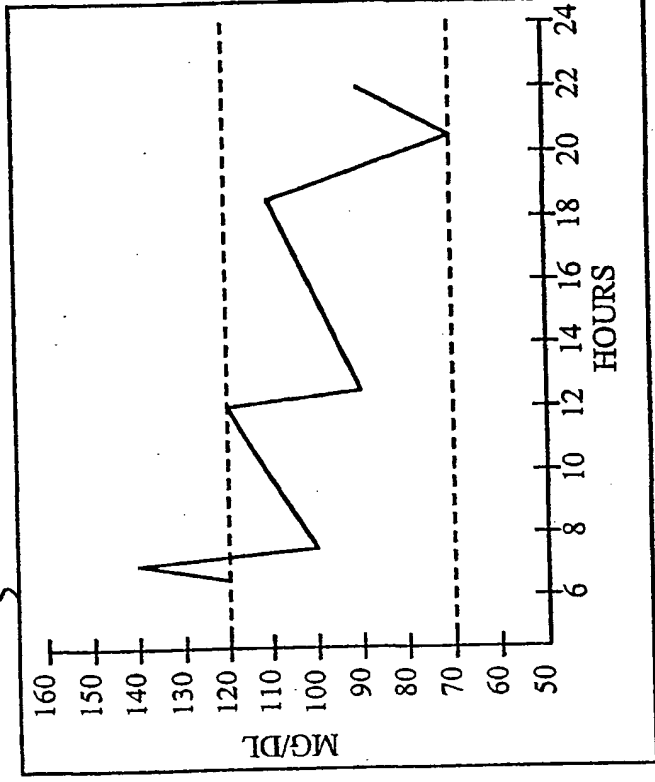

Fig. 10

8/19

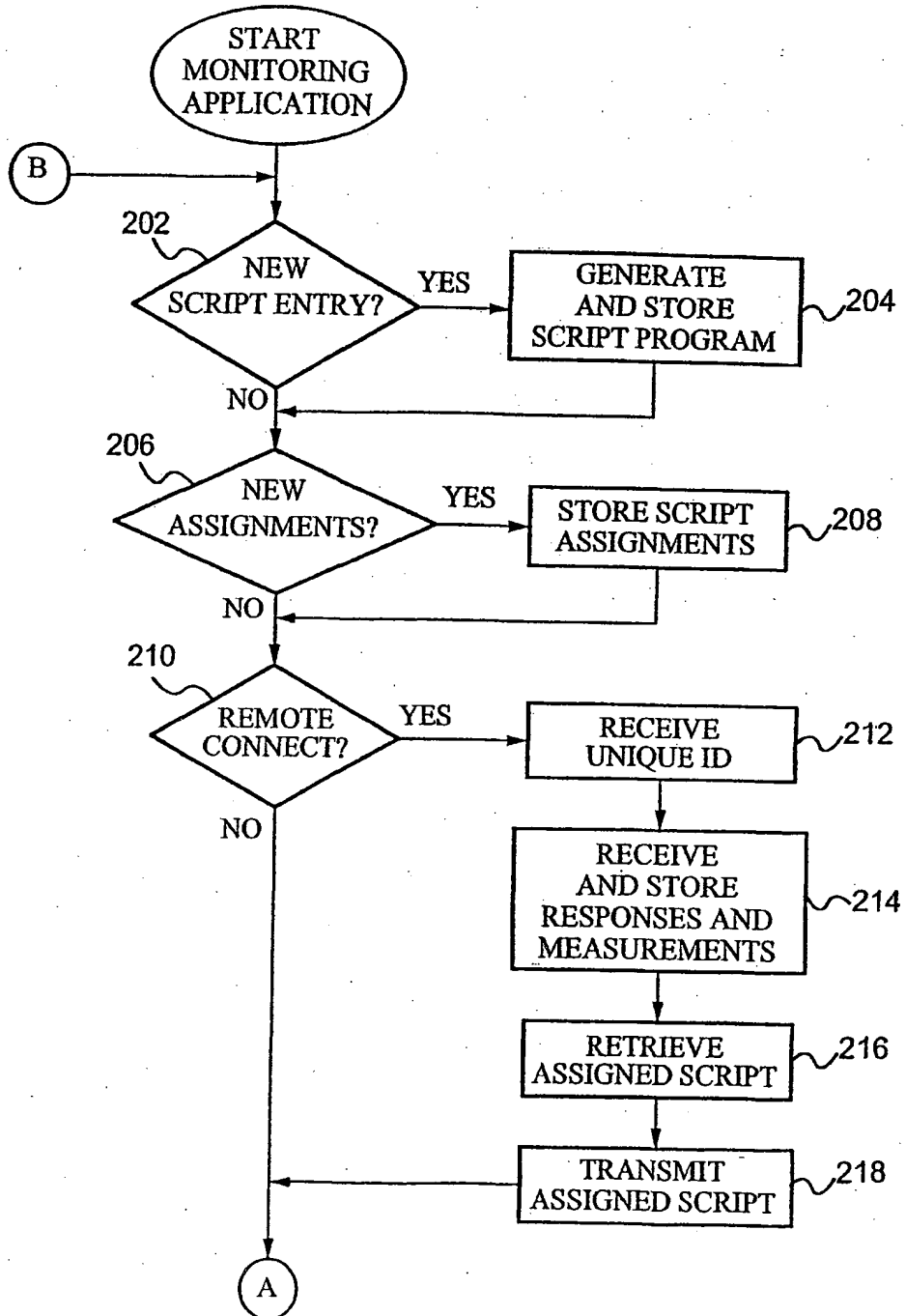

Fig. 11A

9/19

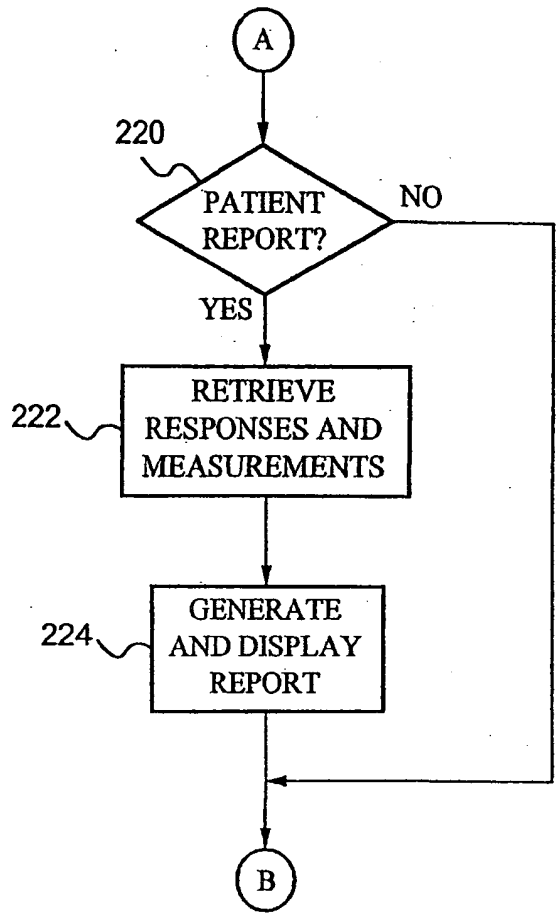

Fig. 11B

10/19

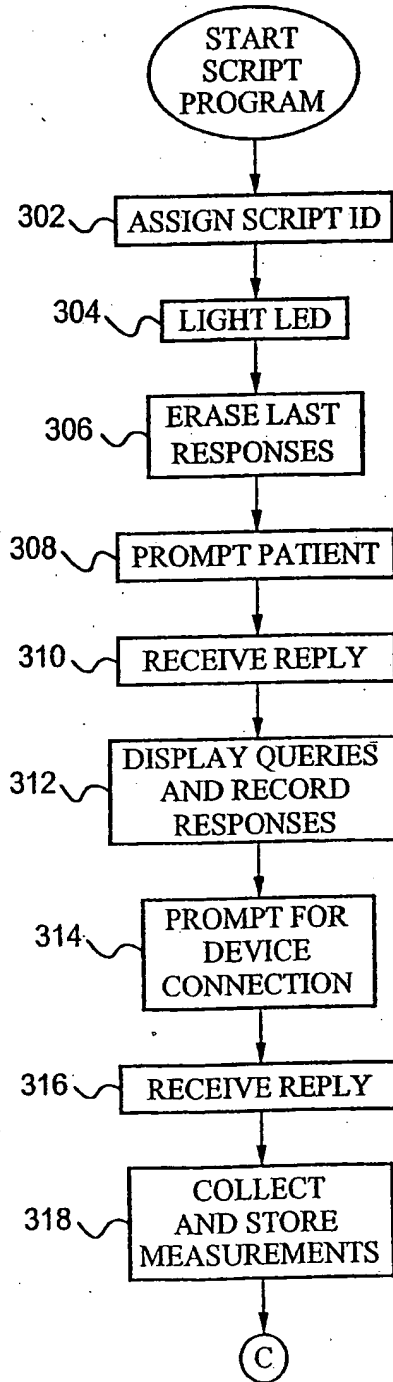

Fig. 12A

11/19

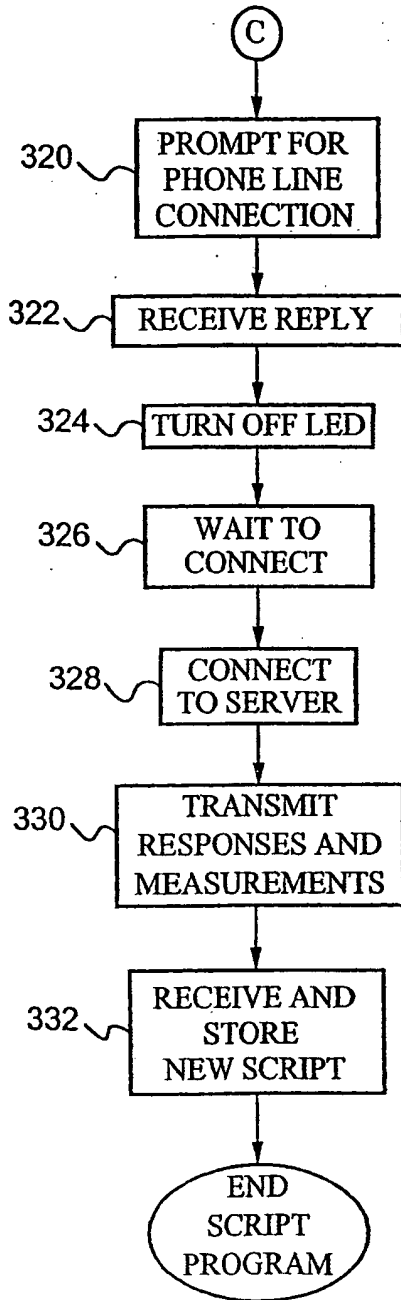

Fig. 12B

12/19

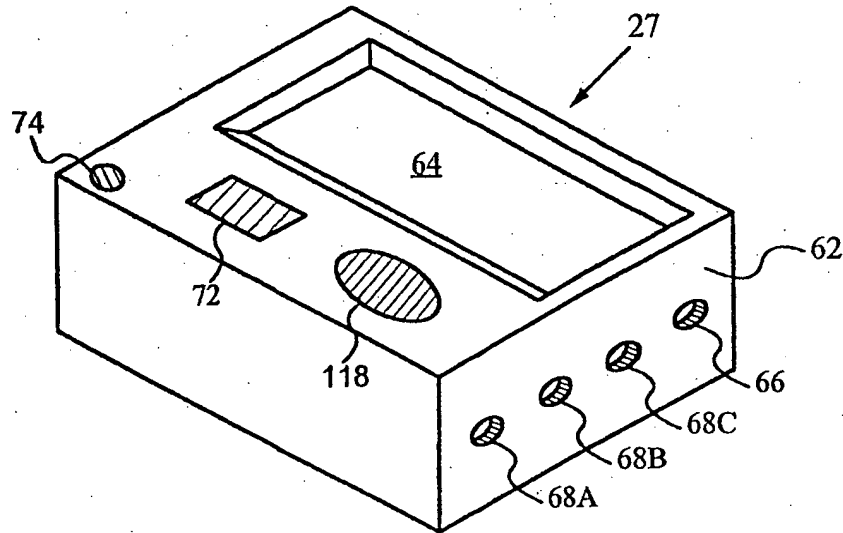

Fig. 13

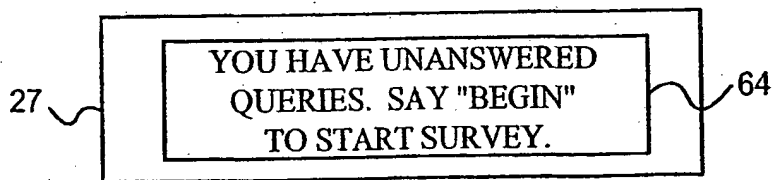

Fig. 14

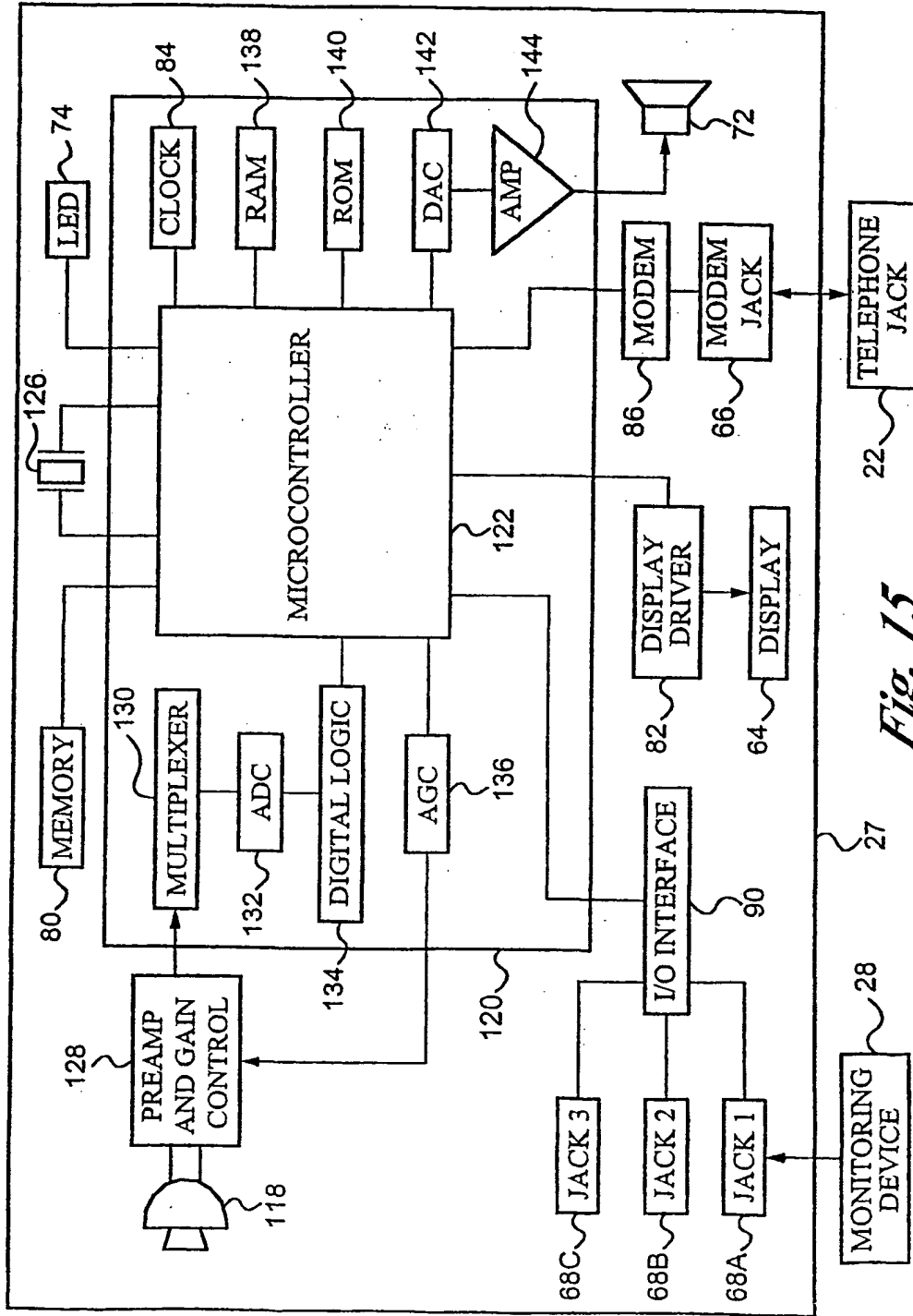

Fig. 15

14/19

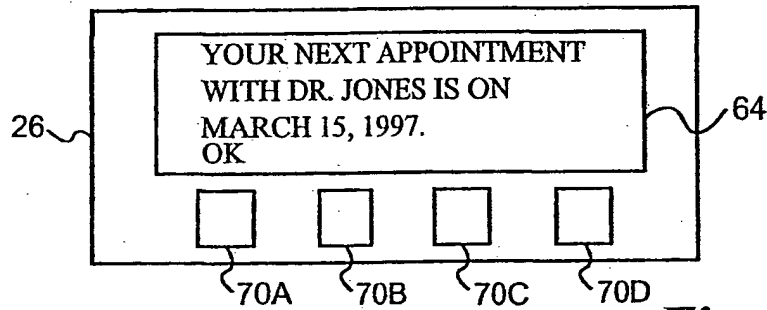
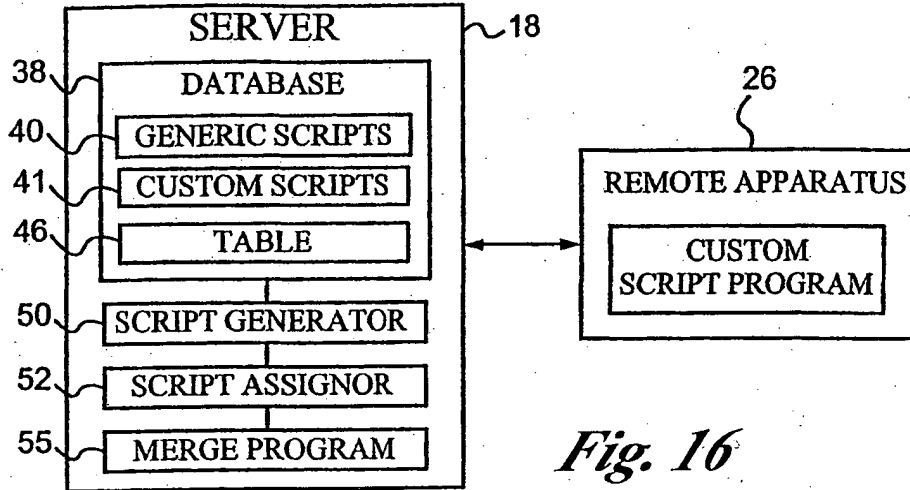

Fig. 17

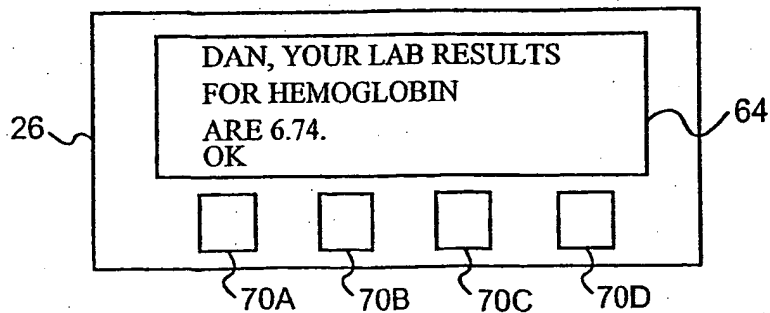

Fig. 18

56 } **SCRIPT ENTRY SCREEN**

SCRIPT NAME: 92

STATEMENTS	CHOICE 1	CHOICE 2	CHOICE 3	CHOICE 4
YOUR NEXT APPOINTMENT WITH <<INSERT PHYSICIAN_NAME>> IS ON <<INSERT APPOINTMENT_DATE>>	OK			
<<INSERT PATIENT_NAME>>, YOUR LAB RESULTS FOR HEMOGLOBIN ARE <<INSERT HbA1c_RESULT>>	OK			
<<INSERT PATIENT_NAME>>, REMEMBER TO EXERCISE CONSISTENTLY	OK			

94 } CONNECTION TIME: 100

102 104

96 }

Fig. 19

16/19

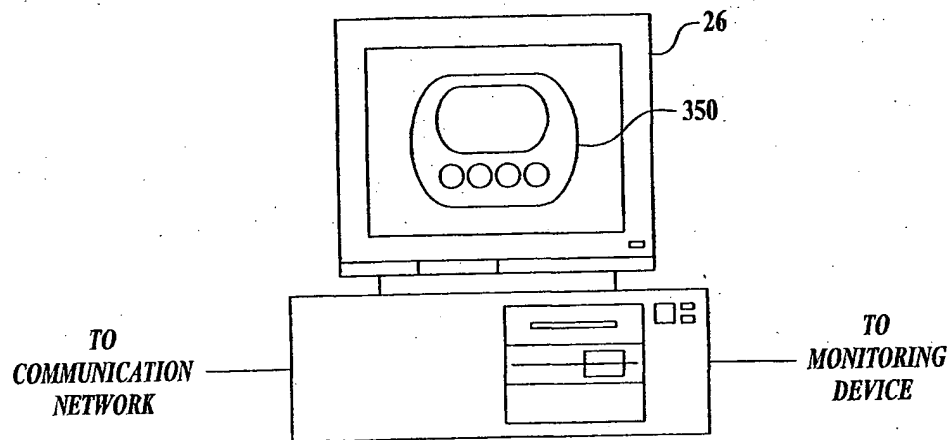

Fig. 20

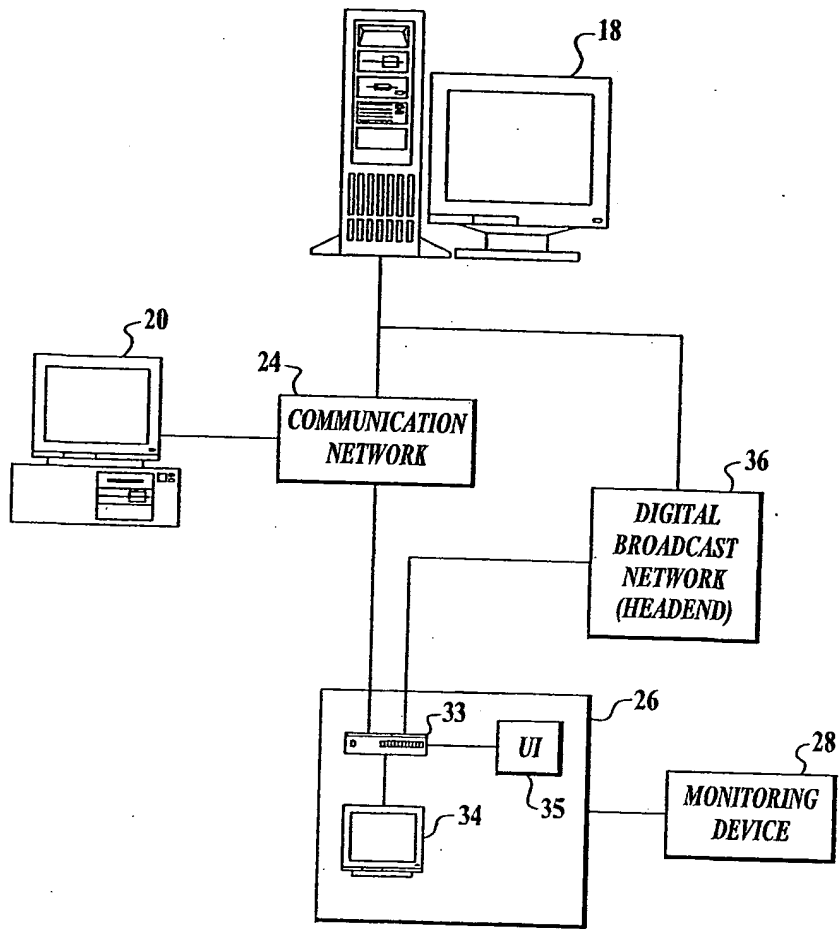

Fig. 21

18/19

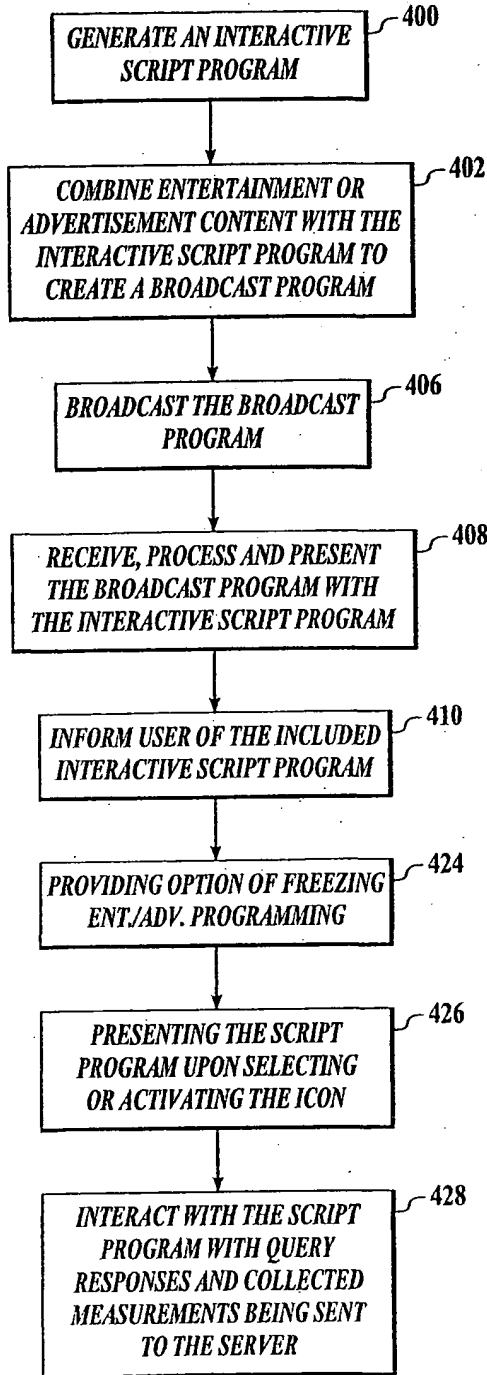

Fig. 22

19/19

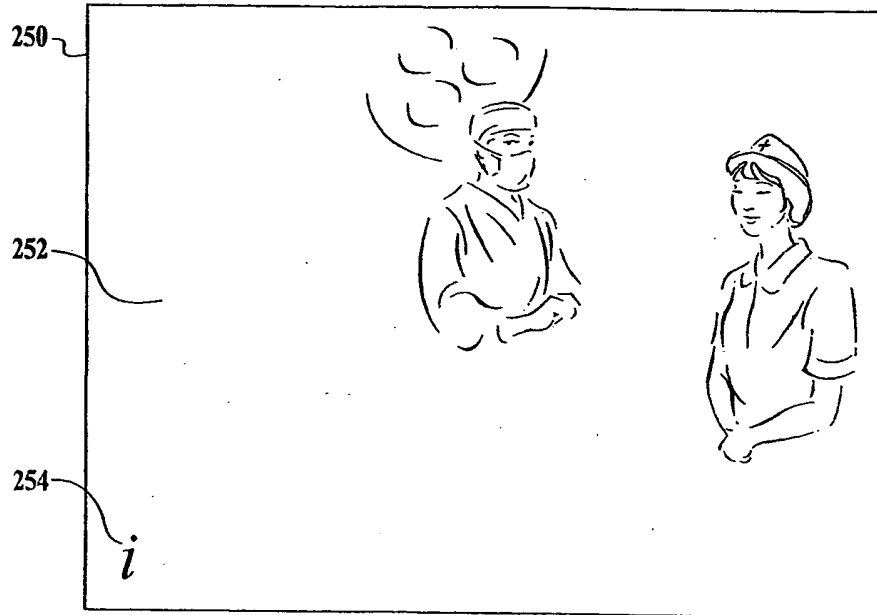

Fig. 23

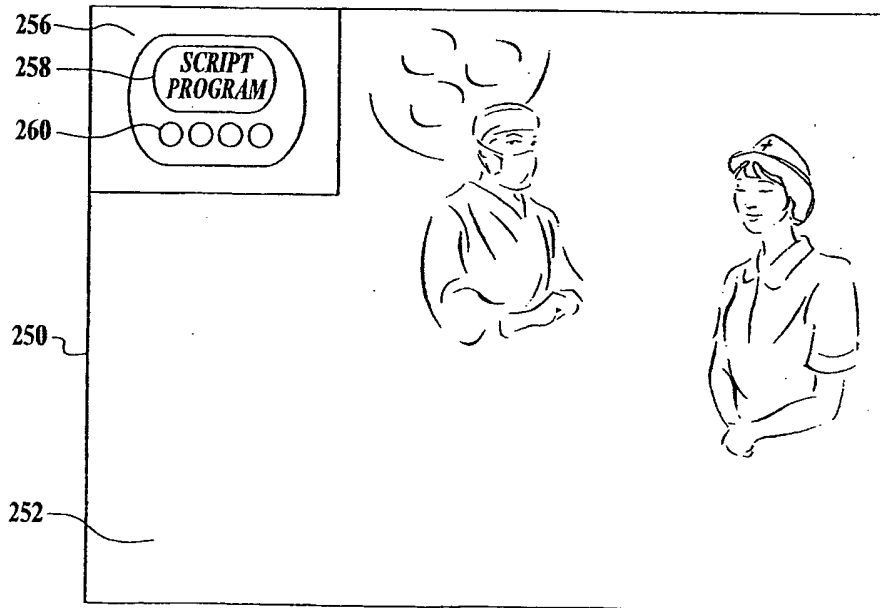

Fig. 24

INTERNATIONAL SEARCH REPORT

International application No.
PCT/US01/09046

A. CLASSIFICATION OF SUBJECT MATTER IPC(7) : G06F 17/60 US CL : 705/4 According to International Patent Classification (IPC) or to both national classification and IPC		
B. FIELDS SEARCHED Minimum documentation searched (classification system followed by classification symbols) U.S. : 705/4, 2, 3 Documentation searched other than minimum documentation to the extent that such documents are included in the fields searched Electronic data base consulted during the international search (name of data base and, where practicable, search terms used) EAST (US Patents, JPO, EPO, Derwent), PROQUEST (all databases)		
C. DOCUMENTS CONSIDERED TO BE RELEVANT		
Category*	Citation of document, with indication, where appropriate, of the relevant passages	Relevant to claim No.
X --- Y	US 5,339,821 A (FUJIMOTO), 23 August 1994, Fig. 1, Fig. 4, col. 3, line 65 - col. 4, line 7, and lines 47-56, col. 5, lines 50-59, and line 64 - col. 6, line 49.	1-3, 5-7, and 9-11 --- 4, 8, and 12-22
Y	US 5,357,427 A (LANGEN et al) 18 October 1994, col. 3, lines 4-28.	4 and 8
Y	US 5,034,807 A (VON KOHORN) 23 July 1991, col. 2, lines 19-57 and col. 19, line 60 - col. 20, line 26.	12-22
A	US 5,897,493 A (BROWN) 27 April 1999, see abstract.	1-22
A	US 5,933,136 A (BROWN) 03 August 1999, see abstract.	1-22
<input checked="" type="checkbox"/> Further documents are listed in the continuation of Box C. <input type="checkbox"/> See patent family annex.		
* Special categories of cited documents: "I" later document published after the international filing date or priority date and not in conflict with the application but cited to understand the principle or theory underlying the invention "A" document defining the general state of the art which is not considered to be of particular relevance "X" document of particular relevance; the claimed invention cannot be considered novel or cannot be considered to involve an inventive step when the document is taken alone "E" earlier document published on or after the international filing date "Y" document of particular relevance; the claimed invention cannot be considered to involve an inventive step when the document is combined with one or more other such documents, such combination being obvious to a person skilled in the art "L" document which may throw doubts on priority claim(s) or which is cited to establish the publication date of another citation or other special reason (as specified) "P" document published prior to the international filing date but later than the priority date claimed "N" document member of the same patent family		
Date of the actual completion of the international search 29 OCTOBER 2001		Date of mailing of the international search report 03 JAN 2002
Name and mailing address of the ISA/US Commissioner of Patents and Trademarks Box PCT Washington, D.C. 20231 Facsimile No. (703) 305-3230		Authorized officer TARIQ HAFIZ <i>James R. Matthews</i> Telephone No. (703) 305-7643

INTERNATIONAL SEARCH REPORT
- Form PCT/ISA/210 (continuation of second sheet) (July 1998)

International application No.
PCT/US01/09046

C (Continuation) DOCUMENTS CONSIDERED TO BE RELEVANT

Category*	Citation of document, with indication, where appropriate, of the relevant passages	Relevant to claim No.
A	US 5,902,234 A (WEBB) 11 May 1999, see abstract.	1-22
A	NOBEL et al. IT helps manage patients with chronic illness. Health Management Technology. December 1999. Vol. 20, No. 11. pages 38-40.	1-22
A	MORRISSEY, JOHN. Web helps nurses manage patients. Modern Healthcare. 07 February 2000. page 73.	1-22
A	ROLLER et al. Eckerd reaches into the home with online network alliance. Drug Store News. 06 March 2000. Vol. 22. No. 3. page 16.	1-22